

**Installation Instructions for the  
Fresco Collection Swing Door Enclosure.**

**Model: FSD**

**Drawing Number: 6171      Rev. Date: 12-08-08**



**Figure #1 - FSD Shower Door Assembly**

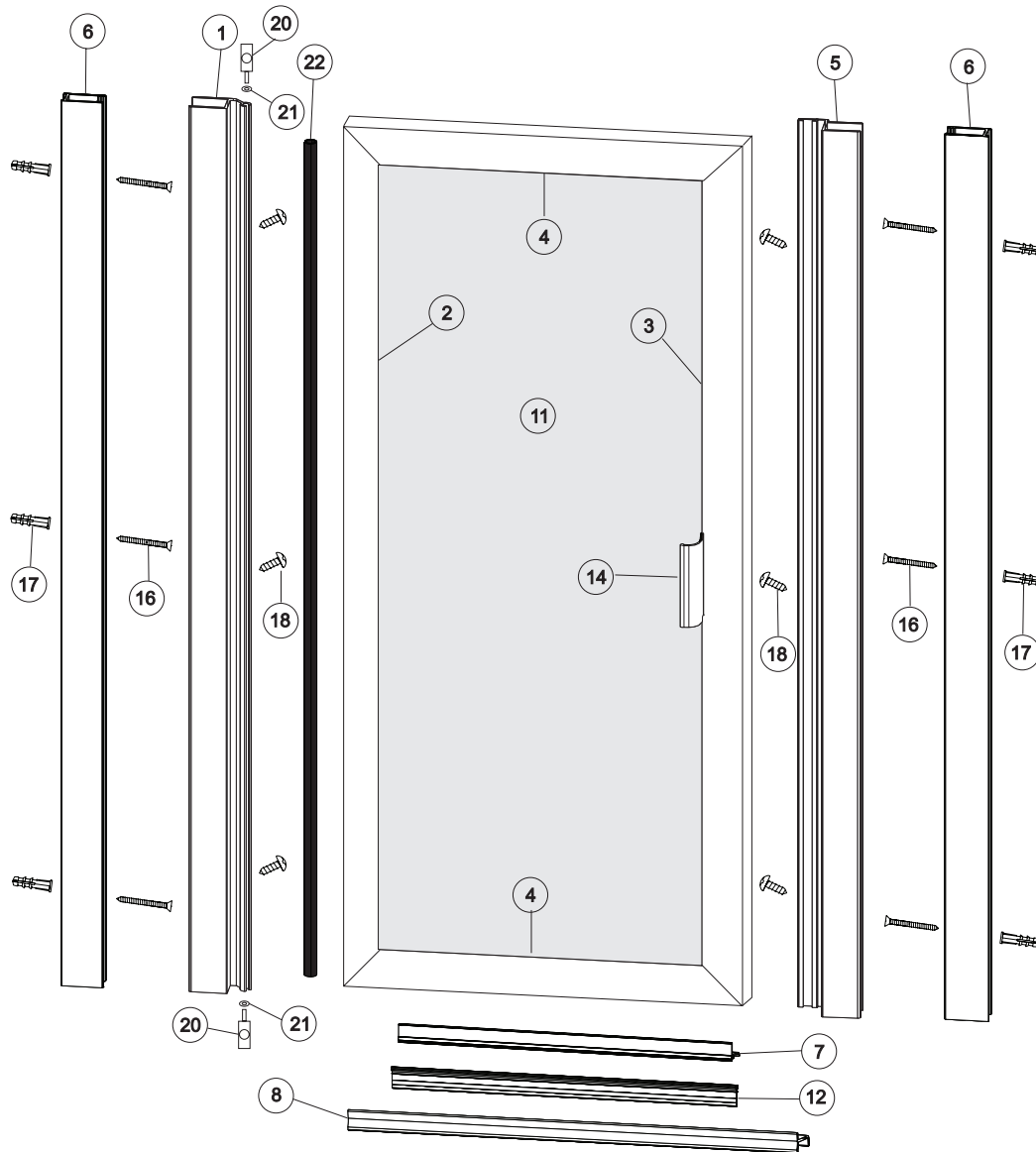

**Figure #2 - FSD Shower Door Assembly - Top View**

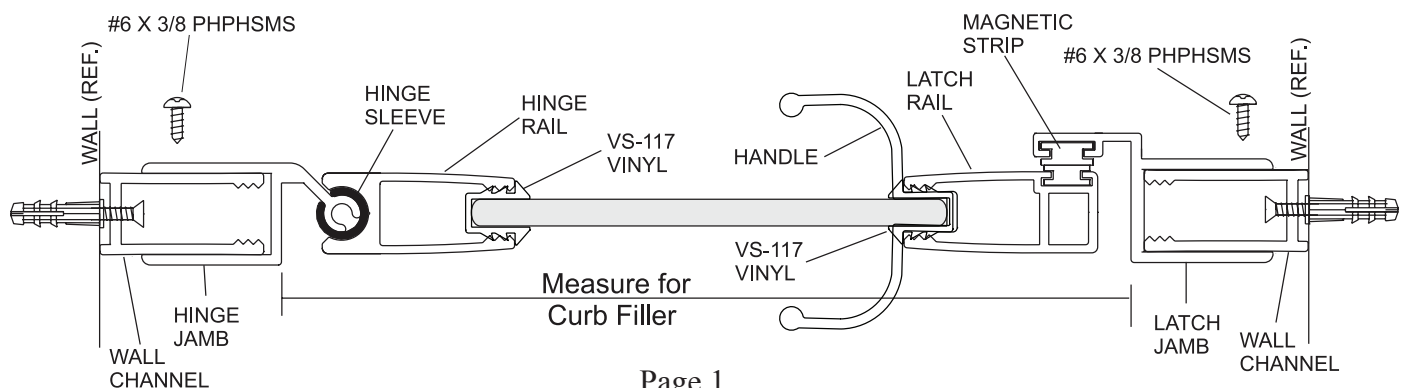

**Installation Instructions for the  
Fresco Collection Swing Door Enclosure.**

**Model: FSD**

**Drawing Number: 6171 Rev. Date: 12-08-08**



**Figure #3 - FSD Side View**

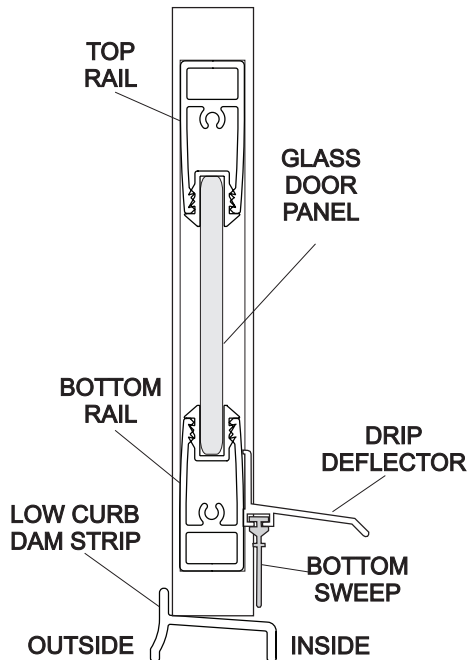

**Figure #4 - FSD Vinyl Notching**

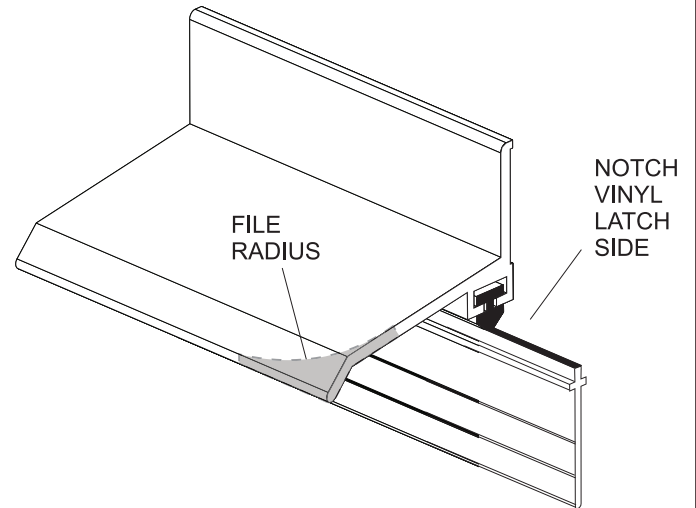

**6171 - FSD Parts List**

ITEM #	PART #	DESCRIPTION	QTY.	ITEM #	PART #	DESCRIPTION	QTY.
1	1165	HINGE JAMB	1	12	4018	VW-2 VINYL SWEEP	1
2	1190	HINGE RAIL	1	13	4008	VS-117 BOOT VINYL	1
3	1191	LATCH RAIL	1	14	1196	HANDLE	1
4	1192	TOP / BOTTOM RAIL	2	15	4023	HANDLE VINYL	1
5	1193	LATCH JAMB	1	16	2101	#8 X 1-1/2 FHPHSMS	6
6	1068	WALL CHANNEL	2	17	2217	3/16" WALL ANCHOR	6
7	1097	DRIP DEFLECTOR	1	18	2102	#6 X 3/8 PHPHSMS	8
8	1019	LOW CURB DAM STRIP	1	19	2122	#6 X 1-1/2 FHSD LEAD PT.	4
9	4100	LATCH RAIL MAGNET	1	20	2001	HINGE PIN	2
10	4100	LATCH JAMB MAGNET	1	21	2002	FLAT WASHER	2
11	7106	GLASS PANEL	1	22	4034	HINGE SLEEVE	1

**6171- FSD Assembly Instructions**

**SAFETY WARNING:**

These installation instructions must be followed to ensure proper operation of the door and to reduce the risk of serious injury. Any deviation from these instructions can result in a serious safety hazard.

All exposed ends of aluminum that are rough, sharp or jagged due to the metal being cut, drilled or damaged should be de-burred, smoothed or rounded by the installer before installation. Failure to do so could result in serious injury to the user of the enclosure.

Any part of the swinging glass panels hitting any unprotected bathroom obstruction or metal or glass component of the shower door itself, may indicate improper installation and could lead to serious injury. Installers must correct the deficiencies before allowing the door to be used.



# Installation Instructions for the Fresco Collection Swing Door Enclosure.

**Model: FSD**

**Drawing Number: 6171      Rev. Date: 12-08-08**



## 6171 - FSD Assembly Instructions

### **NOTE:**

Wall channels are pre-cut to 1 1/16" longer than the Hinge and Latch Jamb. If this is a door only installation, cut the Wall Channels to the same length as the Hinge and Latch Jamb.

### **STEP 1:**

Evaluate your threshold. If an inward slope is not present on the threshold, use the options Low Curb Dam Strip, (ITEM #8) that is included with this product. See (fig. 1)

### **STEP 2:**

If you are using the Dam Strip, measure wall to wall at the base and cut the dam strip 1/16" less than the dimension. The door will be installed on top of the dam strip. If not using the dam strip, start the installation on top of the threshold. Cut 2- Wall Channels, (ITEM #6) down to the same length as the Latch Jamb.

### **STEP 3:**

Start at the Hinge side wall, place one wall channel (ITEM #6), in place. See (FIG. 2) Plumb and mark the hole locations onto the wall. Remove the channel and drill the three holes with a 3/16" drill bit. (use a carbide tipped masonry bit if going into tile or other masonry type products. Insert 3- wall anchors, (ITEM #17). Protect the Wall Anchors and holes from water with sealant. Reposition the Wall Channel and secure it to the wall with 3- #8 X 1-1/2 FHPHSMS, (ITEM #16). Set the second Wall Channel in place, plumb it and mark only the bottom hole at this time. Remove the channel and drill just the bottom hole. Insert a wall anchor, add sealant and secure the bottom of the channel with 1- #8 X 1-1/2 FHPHSMS. Tighten the screw so the channel will stay in place, but can still be moved.

### **STEP 4:**

Slide the Latch Jamb, (ITEM 5), in place over the Wall Channel with only one screw in it, do not secure. Slide the Hinge Jamb and door assembly over the fixed Wall Channel. Adjust the door assembly and Latch Jamb so that they are adjusted approximately the same off of each wall. Use a level placed across the top edge of the door to ensure it is level then starting with the top factory hole in the Hinge Jamb, drill through the factory holes into the Wall Channel with a #32 wire gauge drill bit. Secure the door with 3- #6 X 3/8 PHPHSMS, (ITEM #18).

### **STEP 5:**

Position the Latch Jamb vertically by closing the door and rotating the Latch Jamb and Wall Channel to the door. Find a point on the wall where the door seals full length on the Latch Jamb. Mark the position of the Wall Channel on the wall then remove the Latch Jamb. Rotate the Wall Channel to the mark on the wall and mark the remaining two holes onto the wall. Drill the remaining two holes with the 3/16" drill bit, insert 2- Wall Anchors, (ITEM 17), add sealant, then secure the Jamb Filler with 2- #8 X 1-1/2 FHPHSMS (ITEM #16).

### **STEP 6:**

Set the Latch Jamb back in place over the Wall Channel, do not secure at this time. Close the door against the latch jamb and adjust it until it fully covers the magnets on the door. If the magnets repel each other, slide the magnet out of the Latch Jamb and turn it end for end, then slide it back in. Secure the Latch Jamb by drilling through all three factory pilot holes in the with a #32 wire gauge drill bit and secure with 3- #6 X 3/8 PHPHSMS (ITEM #18).

### **STEP 7:**

Measure the length of the door bottom rail and add 3/8" and cut the deflector to length. File a radius on the sharp corner similar to the factory radius on the other end. Install the bottom weep vinyl, (ITEM #12), into the bottom of the Drip Deflector. Trim leaving 1/4" on each end. Notch the end of the Bottom Sweep where it meets the Latch Jamb as shown in (FIG. 4). Peel the paper off the tape on the Drip Deflector. Stand inside the shower with the door closed, and attach the Drip Deflector to the bottom of the door so that the bottom sweep is within a 1/16" of touching the Dam Strip. If not using the Dam Strip, the bottom sweep should just touch the threshold.

### **STEP 8:**

Run a bead of sealant the full length on the outside of the shower door where the aluminum meets the wall and across the bottom if you are using the Dam Strip.