

PLEASE READ THOROUGHLY BEFORE STARTING INSTALLATION

ITEM#	PART#	DESCRIPTION	QTY
1	1049/1050	Tub Header Left Section	1
2	1049/1050	Tub Header Right Section	1
3	1062	Stay Clean Sill	1
4	1051	Tub Jamb	2
5	1061	90° Tub Post	1
6	1068	Wall Channel	1
7	1070	Panel Sill	1
8	1200	Towel Bar	1
9	3023	Towel Bar Bag	1
10	4031	TF-2BT-Fin	1
11	7302	Sliding Glass Panel	2
12	7106	Side Lite Glass Panel	1
13	2207	AVG-4 Center Guide	1
14	2223	Bumper Guides	4
15	2260	Hanger Bracket Assy	4
16	1089	Horizontal Rail	4
17	1088	Vertical Rail	4
18	4025	VS-13 Glazing Vinyl	4
19	4030	VS-18 Boot Vinyl	2
20	2019	Header Support Clip	2
21	2104	#8x3/4 FHPHSMS	8
22	2101	#8x1-1/2 FHPHSMS	6
23	2217	Wall Anchor	6
24	2102	#6x3/8 PPHSMS	6
25	2203	Setting Block	1
26	2106	#8-32x1/2 FHPHSMS	3
27	2013	Tub Header Clip	4
28	2215	Adjustment Wrench	1



**SAFETY WARNING:**



Agalite enclosures are made with tempered glass which can reduce the risk of injury. However, these instructions must be followed carefully to reduce the risk of serious injury. Any deviation from these instructions can create a serious safety hazard.

All exposed aluminum edges should be deburred to avoid serious injury.

**SPECIAL NOTE:**

Drilling holes and anchoring horizontal sills and curbs to thresholds and tub decks is discouraged. Using masking tape or double-sided tapes to hold these components down during installation is recommended to minimize the potential for water leaking underneath flooring. These instructions do not recommend drilling holes on horizontal surfaces for this reason.

**STEP 1**

**CENTERLINE:**

Locate as accurately as possible the centerline of the shower and mark it with a water soluble marker. In most installations, the Stay Clean Sill (Item #3) is installed over and parallel to the centerline. See Fig. #1. Center the Tub Jamb (Item #4) over the centerline and against the slider side wall. Using a level, plumb the jamb, then mark the bottom hole location only, using the predrilled factory hole as a template. Drill the single bottom hole using a 3/16" drill bit. Use carbide tipped bit if going into tile, marble or any type of masonry material. Insert one Wall Anchor (Item #23) into the hole and secure the Tub Jamb with one #8 X 1-1/2" FHPHSMS (Item #22), installing the screw through the Bumper Guide (Item #14). Tighten screw so that it is snug, but so that the Tub Jamb may be moved side to side at the top. This will allow for final adjustment later. Use two or three strips of masking tape

\* This plan view shows Towel Bar and Pull locations for a shower head that is on the left wall. Please reverse the locations if the shower head is on the right.

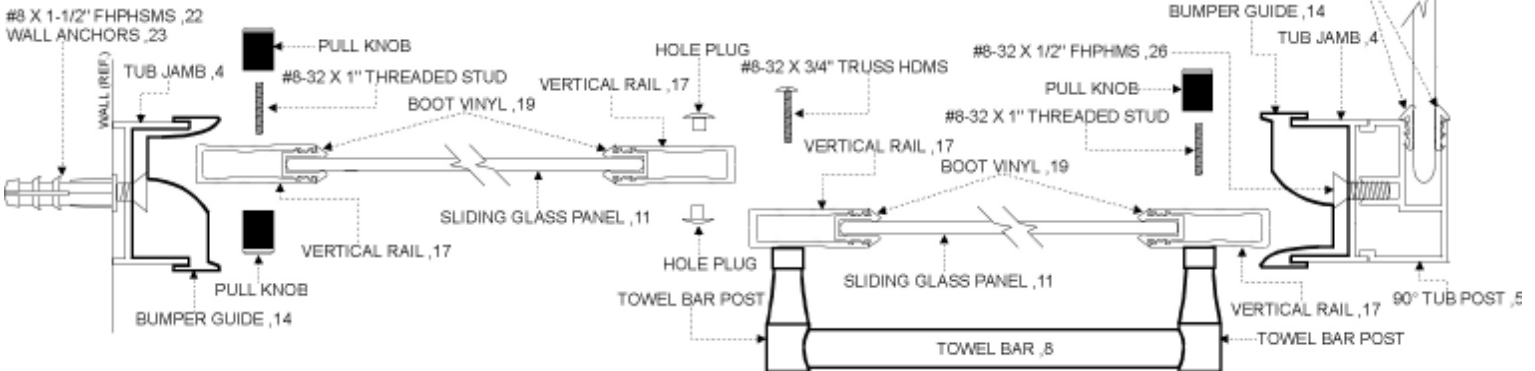

**Fig. #1**

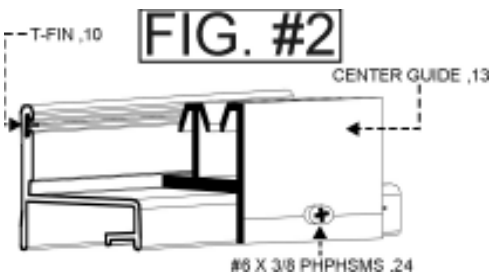

across the Tub Jamb to the wall to hold the jamb from moving during installation.

## STEP 2

### PANEL SILL:

Please note that your Panel Sill may have already been cut to size at the factory. If not, measure the width of the 90° return panel and add 1/4" to this measurement and cut the Panel Sill (Item #7) to length. Set the Panel Sill in place over the return centerline, Mark the location of the sill on the base, then use masking tape to temporarily hold the sill in place.

## STEP 3

### WALL CHANNEL:

Attach the Header Support Clip (Item #20) flush to the top of the Wall Channel (Item

#6) as shown in Fig. #1 & #6. Secure clip with one #6 X 3/8" PPHSMS (Item #24). Set the Wall Channel over the Panel Sill and against the wall, then plumb with a level. Mark the channel's predrilled hole locations on the wall and drill with a 3/16" drill bit. Insert three Wall Anchors (Item #23) then realign the channel with the holes and secure with three #8 X 1-1/2" FHPHSMS (Item #22). Insert a Setting Block (Item #25) into the Panel Sill to protect the bottom of the glass panel. Please note that the Setting Block is oversized so that it may be recut into as many blocks as necessary. Seal both ends of the Panel Sill with silicone then set the 90° Glass Panel into the Panel Sill and into the Wall Channel. Realign sill with index marks. Attach the second Tub Jamb (Item #4) to the 90° Post by positioning it onto the indexing legs of the 90° Post and securing it with three #8-32 X 1/2" FHPHSMS (Item #26). Do this with the top and bottom screw holes by inserting the screws through the Bumper Guide and Tub Jamb into the screw race of the 90° Post. Screw only in the center hole. Tighten until snug. DO

NOT OVER TIGHTEN. Set the 90° Tub Post combination into position over the end of the Panel Sill. Temporarily hold the Post and Glass Panel in a plumb position by inserting one or two inches of Glazing Vinyl (Item #18) into the top of both posts. **NOTE: Do not cut vinyl at this time.**

## STEP 4

### STAY CLEAN SILL:

Measure the distance from inside pocket to inside pocket of the Tub Jamb. This is the installed length of the Stay Clean Sill. Measure and cut Stay Clean Sill (Item #3) to this length. Find the exact middle of the Stay Clean Sill. Using the factory hole in the Center Guide (Item #13) as a template, mark the hole onto the Stay Clean Sill and drill with a #32 wire gauge drill bit. See Fig. #2. **NOTE: Do not attach Center Guide at this time.** Measure and cut the T-Fin (Item #10) to the same length as the Stay Clean Sill. Insert T-Fin into slot located on the inside of vertical leg of sill. See Fig. #2. Set the sill assembly on the shower or tub base by inserting the Stay

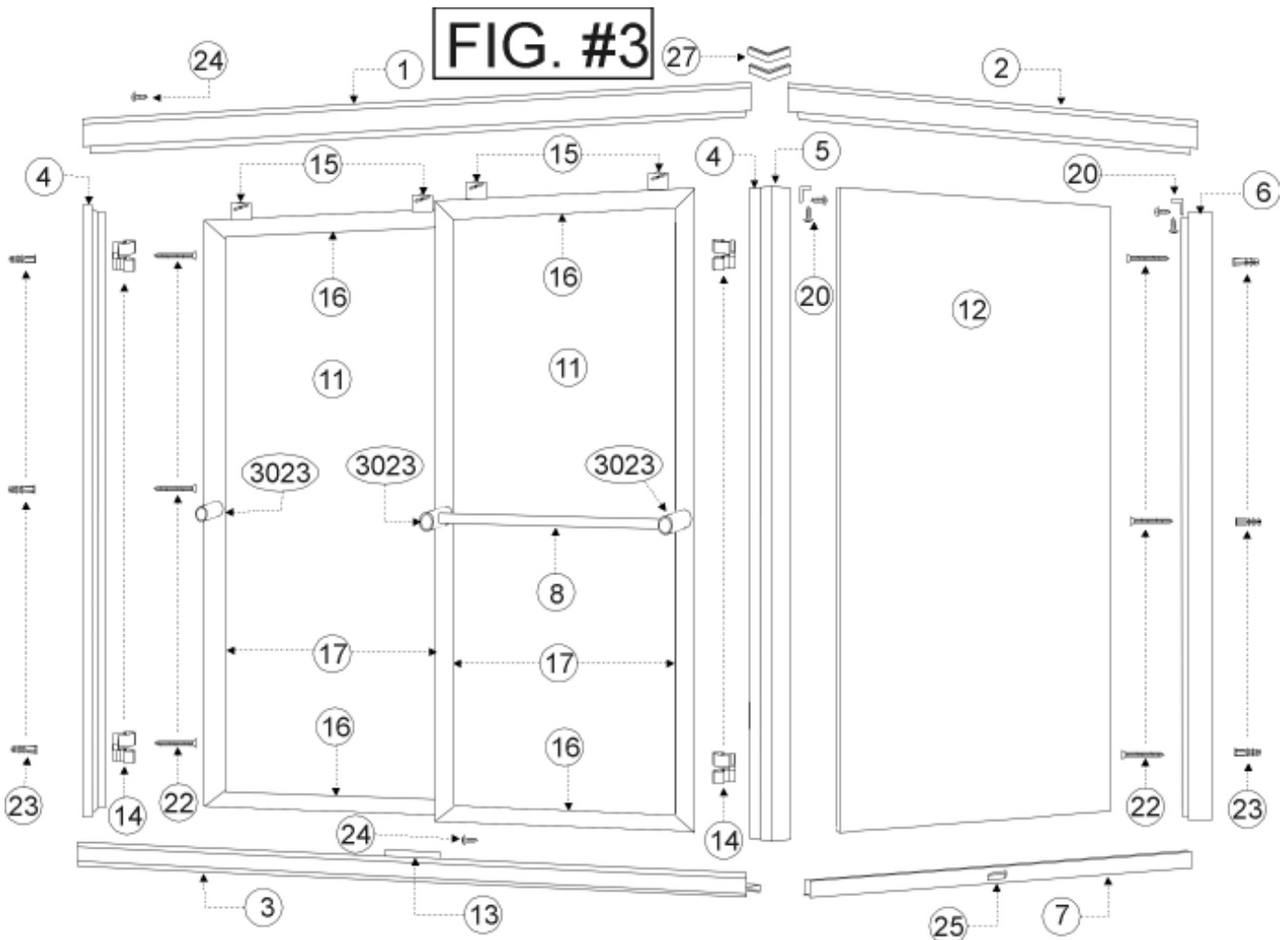

Clean Sill between the legs of the two Tub Jamb and align over centerline. Temporarily hold sill in place with masking tape.

## STEP 5

### TUB HEADERS:

Using a level, plumb the 90° Tub Post in both directions. With the post combination plumb, measure from the outside corner of the post to the wall. Add 1/4" to this measurement and mark it on the header section (Item #1 or #2). Repeat this procedure at the opposite wall and header. **NOTE: All dimensions for the header are measured from the tip (the farthest point) of the 45° miter.** Select the header that is mitered in the right direction for the side that you are measuring. Cut the header to length by cutting the butt end opposite the miter to achieve the finished length. Repeat this procedure for the second Header Section. Assemble the right and left Header Sections with four 90° Tub Header Clips (Item #27) by drilling through the roller channels of the Headers into the Header Clips while holding the miters together. Use an 1/8" drill bit. The holes should be located so that when the screws are installed, they will force the clips apart from one another. See Fig. #4. Secure with four #6 X 3/8" PHPHSMS (Item #24). Set Headers in place over the vertical posts. Secure the Header Assembly to the vertical posts from the inside of the shower by screwing through the factory hole in the Header Support Clip into the bottom of the roller channel of the header with a #6 X 3/8" PHPHSMS (Item #24). See Fig. #5. To anchor the Headers to the 90° Tub Post, install the second Header Support Clip (Item #20), as shown in Fig. #6. Secure with two #6 x 3/8" PHPHSMS (Item #24). Center the 90° Glass Panel between the posts and finish glazing with four pieces VS-13 Glazing Vinyl (Item #18) for the verticals.

## STEP 6

### SLIDING PANEL:

Make sure that the bottom screw in the Tub Jamb that was installed in STEP # 1 is still snug before continuing with this step. Hang the panels in place in the Header starting with what will be the inside panel. Slide it all the way toward the 90° Tub Post, then insert the outside

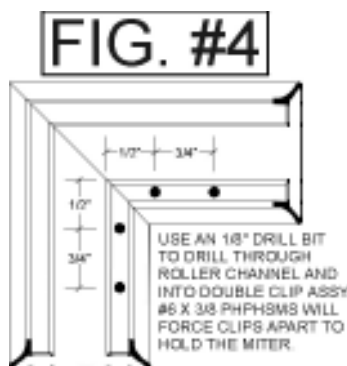

panel and slide it towards the 90° Post. This helps keep the weight of the glass panels away from the unsecured Tub Jamb. Install the Center Guide (Item #13) by sliding the guide between the panels while on the sill. Then secure it with one #6 X 3/8" PHPHSMS (Item #24).

## STEP 7

### PANEL ALIGNMENT:

Standing outside of shower, hold the Header at the top where the unsecured Tub Jamb meets it. **BE VERY CAREFUL NOT TO LET THE PANELS FALL WHILE PROCEEDING WITH THIS STEP.** Slowly move the sliding panels, one at a time, back and forth and into the Tub Jamb, while moving the Header, seeking a point where the panels pocket perfectly into both Tub Jamb. With a pencil, mark the location of the Tub Jamb on the wall. Slide both panels back to the secured Tub Jamb and remove the Center Guide. Remove the panels and set them in a safe place. Move the Tub Jamb back to the marked location on the wall and mark the final two hole locations. Move the Tub Jamb out of the way just far enough to reveal the marked holes, then drill the holes with a 3/16" drill bit. Insert two Wall Anchors (Item #23) into the holes, then realign the holes and secure with two #8 X 1-1/2" FHPHSMS (Item #22) going through the Bumper Guide (Item #14). Reinstall both of the sliding glass panels as in STEP #7 and reinstall the Center Guide.

## STEP 8

### TOWEL BARS AND PULLS:

The inside sliding panel, when closed, must be at the shower head wall so that it can deflect water away from the overlap of the panels at the center of the enclosure. The outside panel must be away from the shower head wall when closed. On the outside sliding glass panel, measure

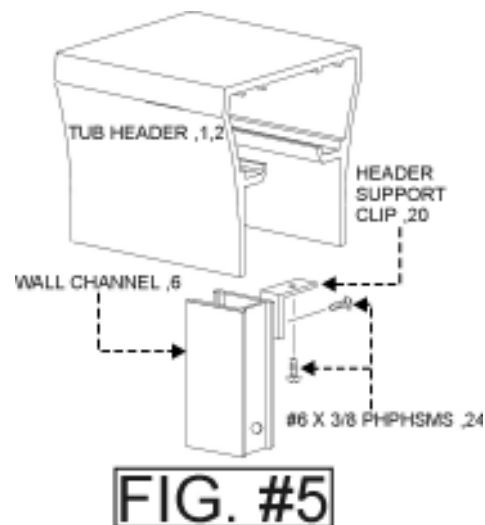

between the towel bar holes in the frame center to center. Cut the Towel Bar (Item #8) to this dimension. For the Pull Assemblies, slide the glass panels to their proper closed position. Notice that the two center holes are inaccessible because of the overlap in the panels. Make them accessible by sliding each panel to the opposite wall. Now the holes are at the outside edges. Please refer to Fig. #1 for proper orientation and installation.

## STEP 9

### PANEL ADJUSTMENT:

If either of the sliding panels is skewed or rubs against the sill, adjust the panels by loosening the hex nut on any of the hanger brackets with the Adjustment Wrench (Item #28) and compensate the panels for the wall conditions. Be sure to retighten all of the nuts. **NOTE: The panels may be adjusted while the panels are installed in the header.** Finish the installation by attaching the Tub Header to the Tub Jamb by drilling (from the inside of the shower) through the Header into the Tub Jamb and secure with one #6 X 3/8" PHPHSMS (Item #24).

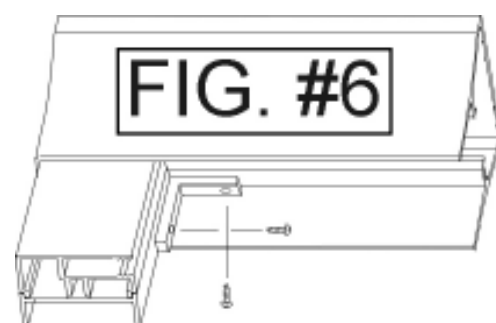

## STEP 10

### SEALANT:

Apply a bead of sealant along the entire inside of the enclosure where it meets the wall or the base. Pay special attention to the corners where the Tub Jambs meet the Stay Clean Sill. This joint must be totally sealed for a leakproof installation.

## STEP-UP INSTALLATION:

### STEP 1

**Fig. A & B:** Follow Step #1 in main instructions.

### STEP 2

**Fig. A:** Measure wall to wall at the threshold, subtract 3/8" and cut Stay Clean Sill to this dimension.

**Fig. B:** Measure the combined widths of the slider glass panels and subtract 7/16" and cut Stay Clean Sill to this dimension.

**Fig. A & B:** Find the exact middle of the Stay Clean Sill. Using the factory hole in the Center Guide (Item #13) as a template, mark the hole onto the Stay Clean Sill and drill with a #32 wire gauge drill bit. **NOTE: Do not attach Center Guide at this time.** Measure and cut the T-Fin (Item #10) to the same length as the Stay Clean Sill.

### STEP 3

**Fig. A:** Attach the second Tub Jamb (Item #4) to the 90° Post by positioning it onto the indexing legs of the 90° Post

flush at the top and securing it with three #8-32 X 1/2" FHPHSMS (Item #26). Do this with the top screw hole by inserting the screws through the Bumper Guide and Tub Jamb into the screw race of the 90° Post. Screw only in the center hole. Tighten until snug. **DO NOT OVER TIGHTEN.** Set the 90° Tub Post combination into position at the step-up and the end of the Panel Sill. Temporarily hold the post and glass panel in a plumb position by inserting 1 or 2 inches of Glazing Vinyl (Item #18) into the top of both posts. **NOTE: Do not cut vinyl at this time.** Plumb, then measure from the post to the wall. Cut the Panel Sill to this dimension. Set Panel Sill in place and hold with masking tape. Seal both ends with silicone. Install the Header Support Clip at the top of the Wall Channel as in STEP #3 in the main instructions. Set Wall Channel in place on top of Panel Sill, plumb, and attach to wall. Insert Setting Block, insert Side lite panel and set 180° Post back in place over glass edge. Temporarily hold in place with a few inches of glazing vinyl.

**Fig B:** Set 180° Post in position over the end of the Stay Clean Sill. Measure from the post to the step-up wall. Cut first Panel Sill to this dimension. Set Panel Sill in place, seal both ends with silicone, then align slider side sill pieces. Set mitered pieces in place, plumb the first piece up the step-up face and align the horizontal Panel Sill. Hold with masking tape then seal both ends with silicone.

Install the Header Support Clip at the top of the Wall Channel as in STEP #3 in the main instructions. Set Wall Channel in place on top of Panel Sill, plumb, and attach to wall. Insert Setting Block then set notched panel in position then follow the the 180° Post. Temporarily hold in place with a few inches of glazing vinyl.

### STEP 4

**Fig. A & B:** Follow steps 5 through 11 in the main instruction sheet.

Please note that the bottom of the side lite panel (in Fig. A only) will be wet sealed by running a bead of silicone inside and out, where the glass enters the panel sill.

