

Features

- 3/16" Frameless Sliding Panels
- 3/16" Sidelite Panels
- Medium Duty 1/2" post system
- Traditional Double Pocket Tub Jamb
- Backed by an industry-leading Lifetime Warranty

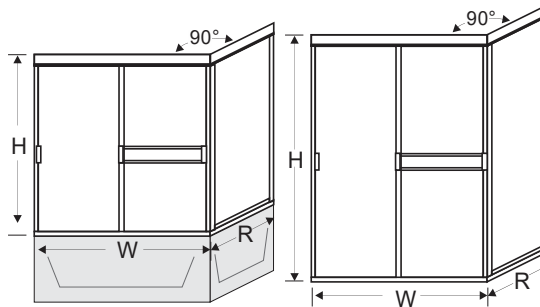

VTE90/VSE90

Includes

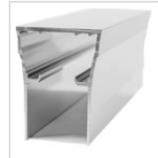

Traditional Cove Header (2,6,7,8)



Double Towel Bar (2,6,7,8)

Height (H) Range:

Tub Enclosure: 56" - 65 15/16"
 Shower Enclosure: 66" - 80 1/2"
 Standard and custom heights available.

Width(W) + Return(R) Range

Total W+R Range: 53" - 120**
 W: 40" - 72"
 R: 5" - 60+"

(both tub and shower enclosures)
 Standard and custom widths available.
 **Wider panels available, call for inquiries on widths extending more than 120".

GLASS OPTIONS (3)

- | | |
|---------|------------|
| Clear | Gluechip |
| Rain | Satin Etch |
| Obscure | Bamboo |
| Gray | |
| Bronze | |
| Velvex | |

EASY CLEAN GLASS (4)

- EasyClean¹⁰ (9) ShowerGuard (10)

FINISH OPTIONS

Standard

- | | |
|-----------------------|-----------------|
| Chrome (6) | Matte Black (8) |
| Oil Rubbed Bronze (8) | Gloss Black (8) |
| Brushed Nickel (7) | White (8) |
| Gold (6) | Almond (8) |
| Satin Silver (6) | |

Special order finishes are available.

(1,2) See below section 4.A., (3) See below section 1.A., (4,9,10) See below section 4.C., (5,6,7,8) See below section 4.B.

Tech Notes

- Screen can hinge off left wall or right. Specify when ordering.
- Unobstructed open door = width (W) - Std Door Size/2 - 2"
- Stock Door Note: Full-height sidelites are for 71" height doors available from 6" to 36" in 1" increments at standard heights
- Doors can be adjusted down in width 1 15/16" (example: 58" door can fit down to a 56" opening with 3" of panel overlap)

1. Quality Assurance

A. Glass door(s) and sidelite(s) use tempered safety glass (see "Features" section for glass thicknesses) and are provided in compliance with ANSI Z.97.1 - 2004, CPSC 16 CFR 1201 Cat. 1 & 2, and ASTM C 1048.

2. Proper Use and Safety

- A. For best results, refrain from drilling holes in horizontal surfaces to secure curbs and sills.
- B. Towel bars, handles and other accessories are in no way considered to be grab bars or other bracing mechanisms.
- C. Exposed ends of aluminum and other hard components can be rough, sharp or jagged due to the process of cutting, drilling, notching, etc. Sharp ends must be deburred, smoothed or rounded by the installer before installation.

3. Warranty

A. Backed by an industry-leading Lifetime Warranty for glass, aluminum and general hardware and 5 Year Warranty on heavy glass hardware (find specific warranty information online at www.agalite.com).

4. Product / Installation

- A. Hardware components and framework are made from 6463 T5 Aluminum Alloy (2), 304 Stainless Steel (1), or Brass (1).
- B. Metal finish processes include plating (5), Brite Dip anodizing (AAMA 611: AA-M21C31A21 Brite Silver, AA-M21C31A23 Brite Gold, AA-M35C11A23 Brushed Nickel, AA-M10C22A31 Satin Silver, AA-M10C22A23 Satin Gold, AA-M10C22A34 Oil Rubbed Bronze) (6), mechanical brushing (7) or powder coating (AAMA 2603) (8).
- C. Easy Clean glass refers to a 10 year coating (TÜV Rheinland Certified) (9) and a permanent glass type (10) that protects the glass against dirt and grime, reducing the effort required to maintain its cleanliness.
- D. Installer shall comply with manufacturer's installation instructions and approved shop drawings.
- E. Prior to installation, verify that surfaces are clean and free of foreign matter that could compromise the watertight bond of unit to surface.