

Installation Instructions for TRTE180/TRSE180 or ECTE180/ECSE180 3/8" Frameless Slider & 180° Panel

FIRST STEPS - Identify the model number of your unit.

- Look on the white shipping label on the outer cardboard box.
- **Model number** on label should correspond to one listed above.

Pick a unit below that best represents your configuration.

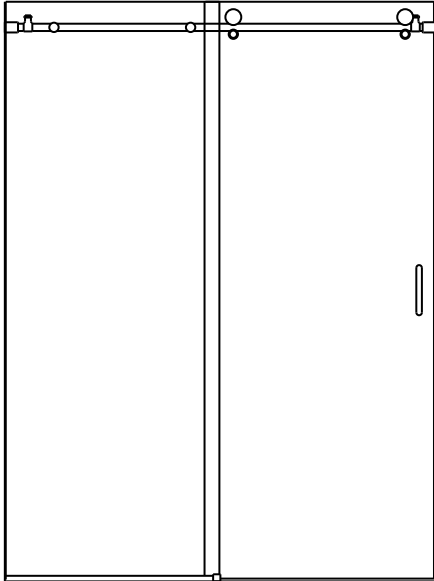

ECSE180
Shower Slider & 180° Panel

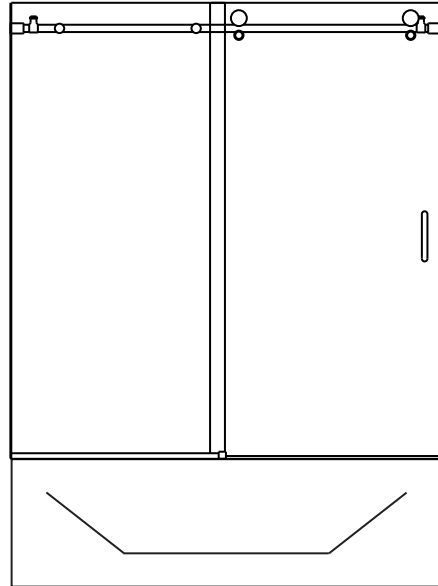

ECTE180
Tub Slider & 180° Panel

NOTE:

- Installation procedures are the same for tub or shower height units
- The images in this manual show an arrangement with the showerhead to the right. The same instructions apply for the opposite orientation where the examples would be reversed.

Required Tools

- * Pencil or water soluble felt pen

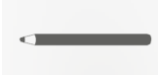

- * Hacksaw with 24 tooth blade

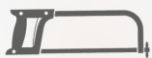

- * Metal file (smooth sharp edges)



- * Tape measure



- * Clear 100% Silicone (recommended)



- * #2 Phillips Screw driver



- * 1/4", 3/8" drill bits (carbide for tile)



- * Caulking gun



- * Drill, electric or battery



- * 4 ft. Level



- * Rubber mallet

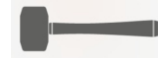

- * Razor knife



READ ENTIRE MANUAL BEFORE INSTALLATION AND OPERATION

Warnings and General Shower Door Information



**SAFETY
WARNINGS:**



READ AND FOLLOW INSTRUCTIONS: Failure to follow all instructions, warnings and guidelines may result in serious injury or death, may cause water damage, and will void the terms of your warranty.

General Safety and Installation Policies

Before Installation:

- **Proper Size:** Ensure the enclosure is the proper size for your opening prior to beginning installation.
- **Safe Installation:** Some units may require two or more people to safely install the enclosure properly.
- **Packaging:** It is recommended to retain all packaging and other materials until installation is complete in the event of a return.
- **Inspect:** Installer should inventory all parts or components and inspect them for damage prior to beginning installation.
- **Sharp Edges:** Exposed ends of aluminum and other hard components can be rough, sharp or jagged due to the processes of cutting, drilling, notching, etc. Sharp ends must be deburred, smoothed or rounded by the installer before installation.
- **Safety equipment and tools:** Have all necessary safety equipment (glasses and gloves) and proper tools for the installation. The installer is responsible for determining the correct drill bit(s) for the installation.
- **New Tile:** We recommend that you allow at least 2 days (48 hours) for the tile cement and grout to dry before installing enclosure.

During Installation



- **Proper backing:** Shower doors are heavy. Therefore, glazing channels, fillers, hinges and headers blocks (structural components) should be secured to studs or solid backing beneath the tile or decorative substrate. Fasteners should screw directly into the backing. Wall anchors are provided primarily to separate screws from tile to reduce the possibility of cracking.

- **Tempered glass:** Glass can break. Shower door panels are tempered to ASTM C1048 specifications as required by building codes. Glass is tempered to greatly increase its strength and to make it fragment into smaller and lighter pieces reducing the possibility of injury in the event that the glass does break. Tempered glass will break and may cause bodily injury if you attempt to cut, drill, mill or alter it in any way. Care must be taken when handling tempered glass. Pay special attention to protect all edges of the glass from contact with hard surfaces.
- **Horizontal surfaces and installation holes:** Avoid drilling into the horizontal surfaces of tubs or showers unless it is required for the structural integrity of the unit. If you drill into horizontal surfaces, always generously caulk the holes, anchors, screws and on top of the screw head. If this is not done, or is done improperly, water damage can occur under the tile or substrate.
- **Weep holes in horizontal channels:** Drilling 3/8" weep holes on the inside of horizontal channels is recommended to allow any moisture build-up inside a channel to exit the channel. Due to varying installation conditions and installer's/owner's personal preference, however, we do not drill them in the factory.
- **Sliding and swinging glass doors:** A door may be improperly installed if it hits or scrapes against bathroom obstructions (toilets or cabinets) or any metal or glass components of the shower door itself. This could lead to glass breakage or serious injury. The installer must correct the deficiencies before allowing the door to be used.
- **Surface conditions:** Most shower door designs allow for out-of-square or unlevel installation. Generally, any outage more than 3/8" that was not identified during the ordering process is outside of these allowances and can result in an improper installation.

Caulking/Siliconing the Unit:

- Always clean all contact surfaces before caulking and use a high grade 100% silicone for best results.
- After installation, at a minimum, caulk the entire outside perimeter of the unit where the unit touches walls, sills, and step-ups, etc. Also caulk any vertical joints between metal components where water build-up inside of the channels could leak out.

After Installation:

- **Curing times:** Adhere to manufacturers' recommended curing times for VHB tapes, silicones and any other adhesives, coatings or chemicals used during installation. Unless otherwise stated, it is recommended to wait 72 hours before using the enclosure.
- **Normal wear and tear:** Although these enclosures are designed to last for years, certain items (such as the polycarbonate seals and door sweeps) may need to be replaced as they show signs of aging and wear.

General Disclaimers

- **Shower Doors are not watertight:** Consumers should understand that a shower door is not watertight. The amount of water that can escape your shower can vary greatly based on shower/tub size, configuration of shower head(s), type of thresholds and drains and by the type of shower door itself. Heavy glass units with no or limited vinyl seals, for example, can allow water to escape under normal conditions. Doors with more metal and seals generally provide more water protection. Excessive water pressure or directing shower heads or hand held sprays directly at doors or joints is not a normal shower conditions and can result in leaks.
- **Towel bars, handles and accessories** are in no way considered to be grab bars or other bracing or fall prevention mechanisms. The intent of these accessories is to facilitate proper operation or enhance the esthetics and functionality of the unit.

Owners Manual:

Refer to your Owners Manual for general installation and cleaning and care instructions. If a copy of the Owners Manual was not included, you can download one on the RESOURCES page of our website.

Questions or Comments:

1-800-843-3332

Installation Instructions

Models: ECTE180 / ECSE180

3/8" Frameless Slider & 180° Panel

Figure 1 - Exploded View

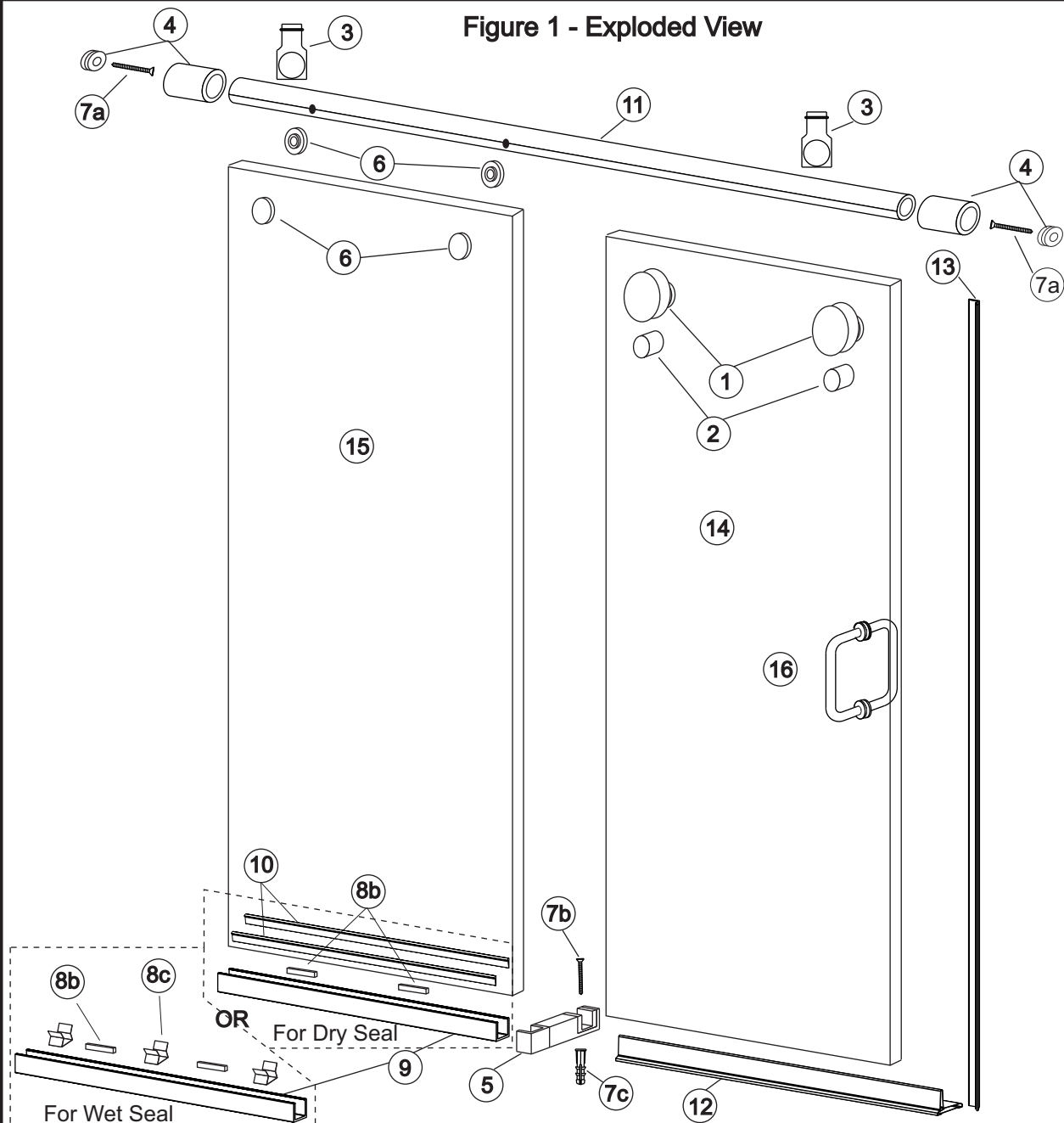

Parts List

HA.3101 Part Box	
1.	HA.3001 - Roller Wheels ----- 2
2.	HA.3002 - Anti Jump Knobs ----- 2
3.	HA.3003 - Bumper Stops ----- 2
4.	HA.3004 - Wall Collars / Pucks ----- 2
5.	HA.3005 - Center Guide ----- 1
6.	HA.3007 - Panel Connectors ----- 2
7.	BP.5001 - Part Bag ----- 1
7a.	M6 - 1.75 X 60mm Screw ----- 2
7b.	#10 X 1-1/8" 16tpi Screw ----- 1
7c.	#10 X 1- 3/8" Wall Anchors ---- 1
7d.	6mm Allen Wrench ----- 1
7e.	4mm Allen Wrench ----- 1
7f.	3mm Allen Wrench ----- 2

BP.5004.NTL - Part Bag	
8a.	BP.3027.SIL (Parts Kit) ----- 1 Bag
8b.	BP.3028.NTL Setting Blocks- 1 Bag
8c.	SP.2221.CLR Centering Clips ---- 3
8d.	MM.5004 Inst. sheet ----- 1

Other Major Components	
9.	EX.1018 - Panel Sill ----- 1
10.	VN.4031 - Snap Vinyl ----- 2
11.	HA.30XX - Header Tube ----- 1
12.	VN.4304 - Soft Sill ----- 1
13.	VN.4083 - Vertical edge seal ----- 1
14.	Sliding Panel ----- 1
15.	Fixed Panel ----- 1
16.	HA.270X - 8" Handle ----- 1

Full Size Drawings:

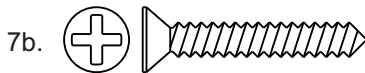
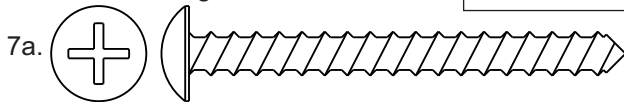

Extra screws may be provided for your convenience

Installation Instructions

Models: ECTE180 / ECSE180

3/8" Frameless Slider & 180° Panel

STEP 1 - Calculation:

- * Measure height of sliding glass panels (14): _____
- * Subtract 3 1/16" from this measurement: _____
- * New measurement is the height from the threshold to the center of the first Wall Puck Step 3.

Slider panel height - 3 1/16 = _____

STEP 2 - Evaluate Threshold:

- * Maximum recommended vertical threshold outage from side to side is 1/4".
- * If needed, mark high-side and low-side of threshold.
- * First puck will be installed on high-side wall, or stationary panel side if threshold is level.
- * **NOTE:** Set sliding panel (14) inside shower before proceeding.

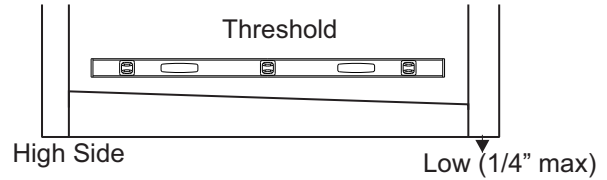

STEP 3 - Determine Centerline on Threshold and Walls:

- * Mark Center Guide (5) location on threshold.
- * To determine Centerline location, center the guide at center of threshold width and depth.

Do not install! Location will shift during final adjustments.

- * Wall pucks will be centered on the centerline of unit.
- * Laser or plumb-bob is handy to determine and mark the overall centerline of the unit. See Detail A

STEP 4 - Mount First Wall Puck on "High Side" wall:

- * Measure up from the threshold, the distance determined in Step 1. Center Puck on the Centerline with the slot in the vertical position and mark the hole location. See Detail B.
- * Drill with a 3/16" drill bit. Enlarge hole through tile with 5/16" carbide bit to ensure screw will not crack tile.
- * Install the Wall Puck (4 inside) with one M6 X 50mm screw, (7a).
- * Attach Wall Collar onto puck and tighten set screws to secure Wall Collar, (4) in place.
- * Sequence tightening of set screws as shown for best results.

STEP 5 A - Check Header Tube Length:

- * The header may already be cut to length from the factory
- * To check measure wall to wall just below the Wall Pucks and subtract 1 1/2". If your tube is this length, proceed to STEP 6. If not, proceed to STEP 5B.

STEP 5 B - Cut Header Tube Length (figure C):

- * Measure wall to wall just below the Wall Pucks and subtract 1 3/4". This dimension will be the final length to cut the header tube (11).
- * **IMPORTANT:** The tube must be cut off from the end of the tube that is furthest AWAY from the holes in the tube.
- * Cut the tube to length with a hack saw.

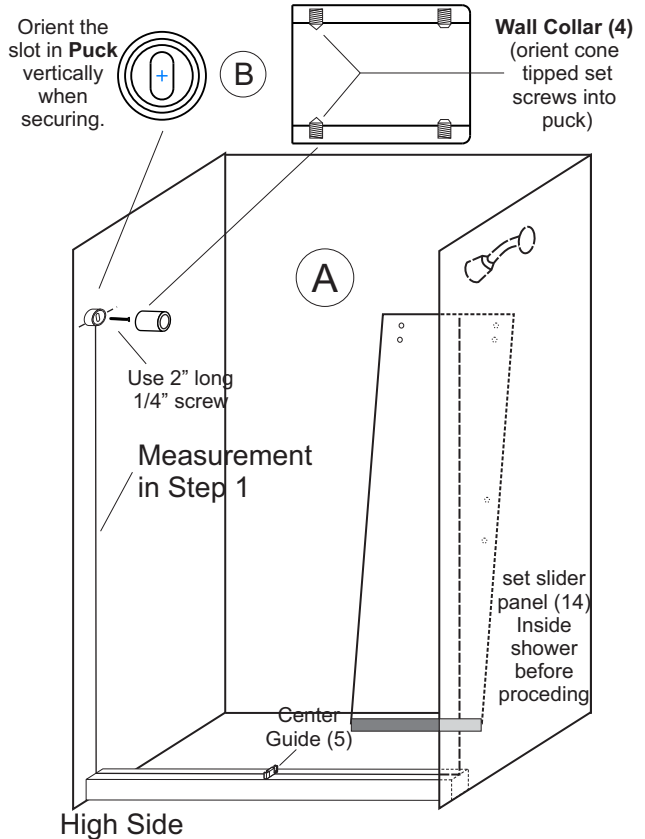

(C)

For STEP 5 B only

Cut from end that is opposite from the holes in the tube

Measure Wall to Wall just below wall pucks subtract 1 3/4"

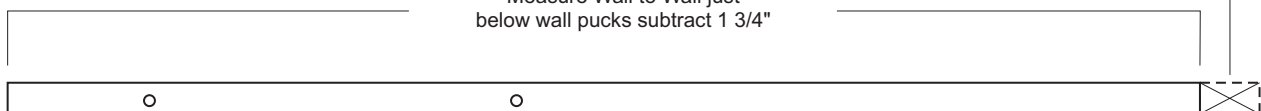

Installation Instructions

Models: ECTE180 / ECSE180

3/8" Frameless Slider & 180° Panel

STEP 6 - Install Panel Connectors on Header Tube:

- * Orient Header Tube (11) so that the two holes are facing up.
- * Insert a screwdriver into the center hole of the tube.
- * Slide a Plug into tube stopping it with the screwdriver.
- * Manipulate the plug so that the hole in the plug lines up with the hole in the tube.
- * Put the screw through connector plate and into plug.
- * Snug screws with the supplied Allen wrench.
- * Repeat this procedure with the second hole closest to the end of the tube. See Detail D.

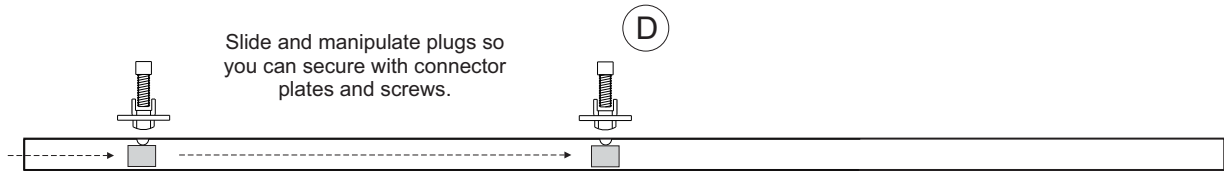
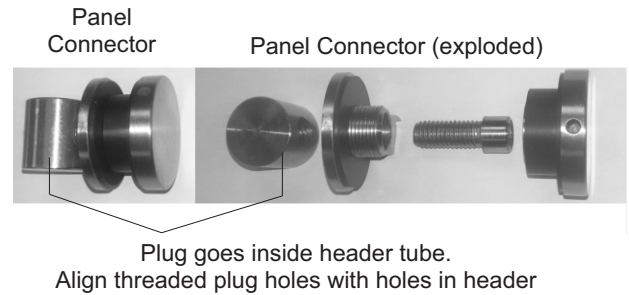

STEP 7 - Install Stoppers and Wall Collar on Header Tube:

- * Carefully slide stopper to initial locations about 3" onto the tube.
- * Take care not to scratch the tube.
- * Lightly tighten stopper set screw or secure with painter's tape so stoppers do not slide and scratch the tube.
- * Final position will be determined during later steps.
- * Opposite Side Wall Collar:
 - Slide other wall collar onto the opposite side of tube. See Detail E.

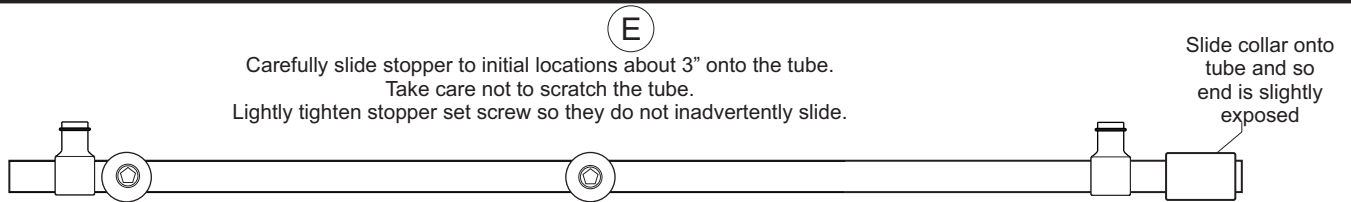
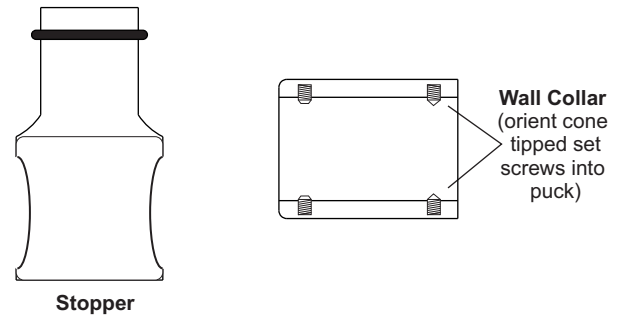

STEP 8 - Mount Second Puck on Opposite Wall:

- * **THIS STEP REQUIRES ASSISTANCE**
 - Carefully lift wall tube assembly and insert the open tube end into the puck/collar already mounted on the wall (high side).
 - Take the second puck and hold it butted to the loose to end of the header tube and against wall on the centerline.
 - Level the tube with a level and mark the outline of the puck.
 - Remove tube assembly and mark puck slot on the centerline (keep slot vertical)
- * Drill your mark with a 3/16" bit.
- * Enlarge hole through tile with 5/16" carbide bit (to ensure screw will not crack tile).
- * Secure the Wall Puck (4) with one M6 X 50mm screw, (7a).

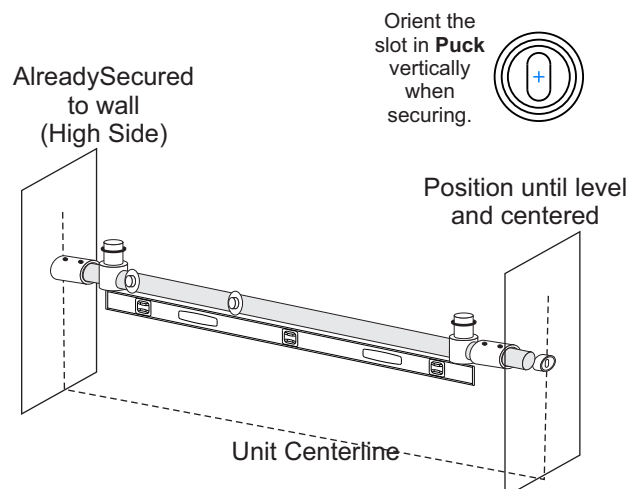

Installation Instructions

Models: ECTE180 / ECSE180

3/8" Frameless Slider & 180° Panel

STEP 9 - Mount Header Tube:

- * Slide the Header Tube into wall collar with stoppers pointed up.
- * Slide the loose Wall Collar off the Header Tube and onto the opposite Wall Puck taking care the tube does not fall.
- * Center the Header tube within both Wall Collars and align the Panel Fixers so they are facing to the outside.
- * Secure tube by tightening the set screws on each collar in the order shown (for best results).

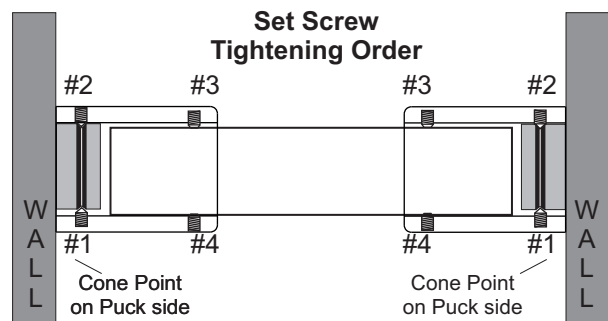
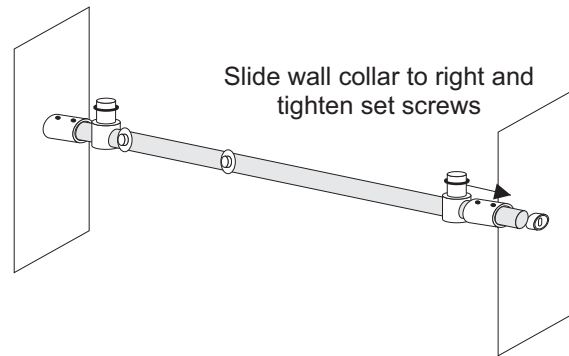

STEP 10 - Preparing and Positioning Bottom Channel:

- * Prepare Bottom Channel (9):
 - The Bottom Channel (9), may already be cut to size.
 - If not, measure the width of the Fixed Glass Panel (15) and subtract 3/4".
 - Cut the EX.1018 Panel Sill, (9) to this length.
 - Insert two 1/8" Clear Setting Blocks (8b).

* **NOTE:** Choose the Bottom Channel glazing method:

- **DRY SEAL:** Will use two pieces of Snap Vinyl after Glass Panel is in final position.
OR
- **WET SEAL:** In addition to the Setting Blocks, also insert three Centering Clips (8c) into the sill between setting blocks. You will have to silicone glaze both sides of the panel to the Bottom Channel after Panel is in final position.

* Position Bottom Channel:

- Butt bottom channel to wall in front of Centerline.
- Securely tape into position with blue painter's tape on the inside and outside to ensure it channel does not slip when you put the panel in.
- **NOTE:** You will have to adjust the position of the channel forward or backward during installation.



Cut the EX.1018 Panel Sill
Fixed Panel Width - 3/4"

Choose Glazing Method

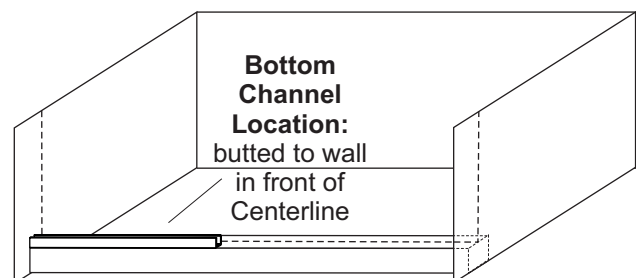
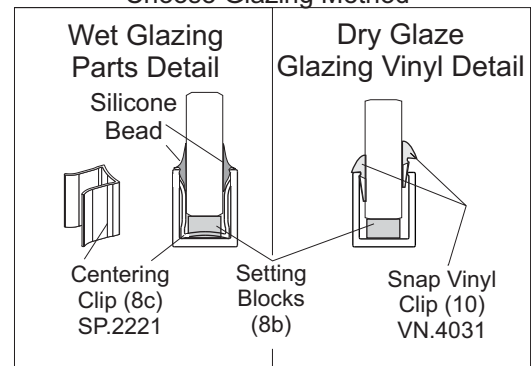

Installation Instructions

Models: ECTE180 / ECSE180

3/8" Frameless Slider & 180° Panel

STEP 11 - Mounting the Fixed Glass Panel:

- * Set the Fixed Panel into the Panel Sill:
 - Spaced panel 1/8" off of the wall.
 - **NOTE:** 1/8" gap will be filled with silicone during final steps of installation.
 - The Fixed Panel will protrude out of the end of the channel.
- * Holes in the glass should line up with the two Panel Connectors on the Header Tube.
- * If they don't, you may have to raise or lower the Panel by adjusting the Setting Blocks
- * And / Or, adjust puck slot on the wall to raise or lower Tube to adjust up and down and possibly rotate the Header Tube to square it up to the panel.
- * After the panel is adjusted, secure the Panel to the Header Tube with Panel Connector Cap. Tighten securely using Allen wrenches supplied.
- * With the top of the Panel secured:
 - Loosen blue tape
 - Use a rubber mallet and tap the Panel Sill and the panel at the bottom to the plumb position using a level.
- * Securely tape bottom channel to floor with painter's tape.

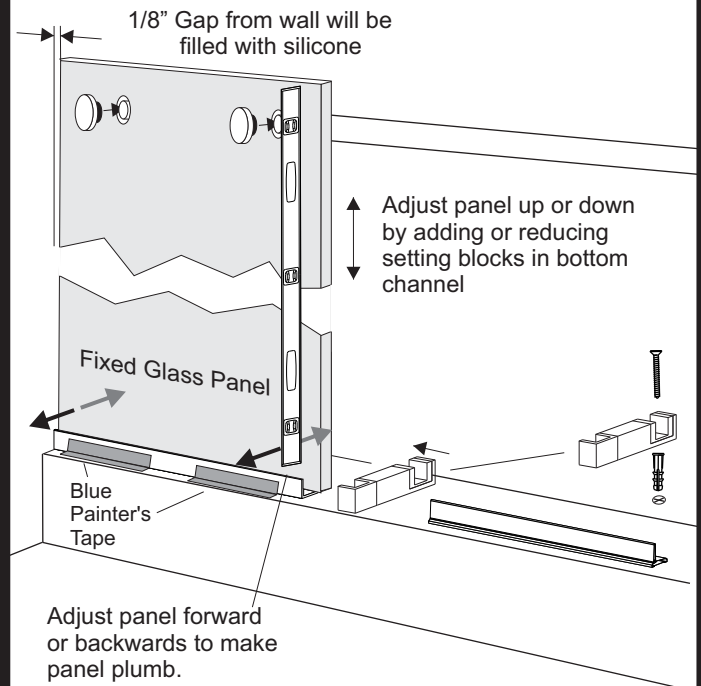

STEP 12 - Center Guide:

- * Set the Center Guide (5) in place on the threshold and over the edge of the Fixed Panel.
- * **NOTE:** The Center Guide is reversible by loosening the set screw and rotating the receiver.
 - Open "C" without black insert cups over the exposed edge of panel.
 - Black insert side should point up and be positioned to the inside of units as shown.
- * Mark the hole location and drill with a 3/16" Drill bit. Insert Wall Anchor (7c).
- * Fill Wall Anchor and hole with silicone and put a bead on the bottom of the Guide.
- * Secure guide with one #8 X 1-1/8 FPHP Screw (7b).

STEP 13 - Mounting the Sliding Panels:

- * Take the Inside Sliding Panel (14), mount 2 Wheel assemblies (1) as shown.
- * **NOTE:** The Wheel will face to the outside of the shower.
- * By rotating plate between roller and glass, adjust the roller so you have equal up and down adjustment.
- * **NOTE:** Once roller is adjusted to desired height, ensure inner plate is not rotated.
- * Tighten the roller securely as shown by rotating back cap.
- * Repeat for second roller (1). Tighten the rollers securely using the two 3mm Allen Wrenches (7f).

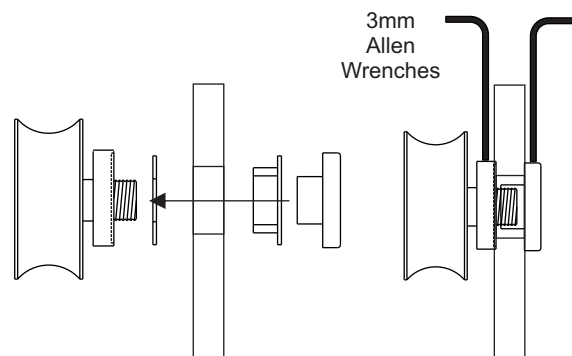

Installation Instructions

Models: ECTE180 / ECSE180

3/8" Frameless Slider & 180° Panel

STEP 14 - Hanging and Adjusting the Sliding Panel:

- * From inside of the shower, carefully lift Sliding Panel (14) onto the Header Tube (11) and into the Center Guide (5).
- * Move each Bumper Stop (3) towards the walls.
- * **Shower Head Wall:** bring the Sliding Panel to the closed position, leaving an even 1/4" gap at the shower head wall.
- * NOTE: you may have to individually adjust the rollers up or down if wall and the edge of panel does not have equal reveal from top to bottom.
- * Secure bumper stop by tightening set screw located at the top of the bumper stop. Tighten this well!
- * **Stationary Panel Wall:** slide the sliding panel (14) to the open position behind stationary panel (15).
- * Slide the bumper stop to stop the roller:
 - at least 1" from center of handle holes
- OR
- so the back edge of sliding panel is 5/8" or more from the wall.
- WHICHEVER HAPPENS FIRST
- * Tighten second bumper stop well!

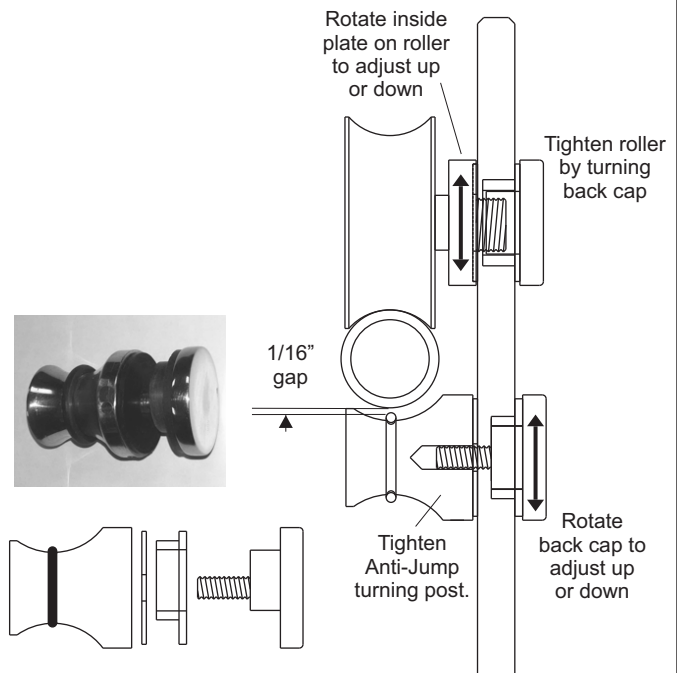

STEP 15 - Anti Jump Posts (2):

- * Install Anti Jump Posts as shown.
- * Adjust posts until they come within 1/16" of the bottom of the bar.
- * NOTE: Test to make sure the anti-jumps restrict the rollers from coming off the tube.
- * Tighten Anti-Jump post securely, holding the back cap in adjusted location.

STEP 16 - Install Handle (16):

- * Install handle with instructions provided.
- * Ensure handle does not hit stationary glass panel.

STEP 17 - Install Bumper Seal (13):

- * Measure sliding panel top to bottom, deduct 1/8"
- * Cut bumper seal (13) to this length and tap it onto edge of sliding panel (14) on shower head side.



STEP 18 - Soft Sill (12):

- * Measure from center guide to wall and deduct 1/16"
- * Clean adhesion area under Soft Sill with alcohol and dry.
- * Cut Soft Sill to dimension. Peel the backing off the tape on the sill and stick in place.



STEP 17 - Final Glazing/Silicone: GE1200 Recommended

- * Run a bead of Silicone vertically to seal the panel (15) to the wall. Blue Painters tape is recommended to assist in this step
- * Install Snap Vinyl (10) or run a bead of Silicone along the horizontal edge of the of bottom channel where it meets the glass panel, and along the entire inside and outside of threshold.
- * Silicone gaps between center guide and glass.
- * NOTE: Let silicone dry and tape cure for 24 hours before use.

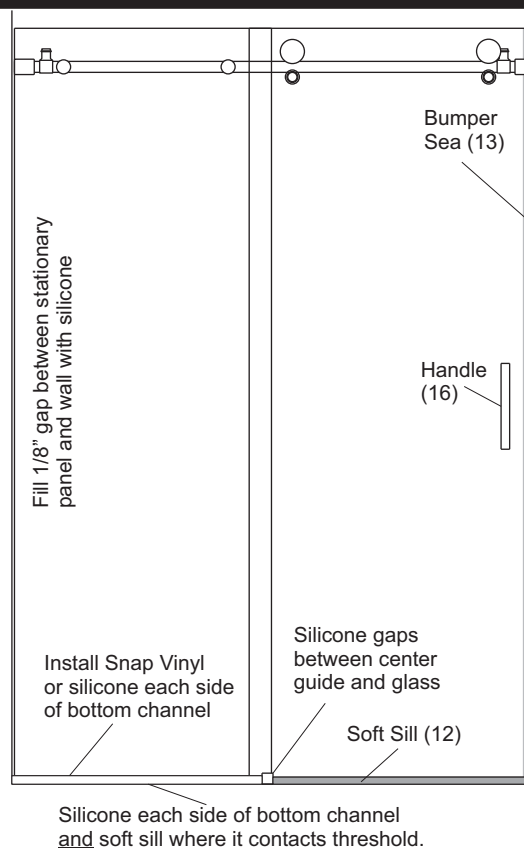

Placement and Measuring Guide for TRSE180 or ECSE180 Bypass Sider

This flyer should be integrated with the TRSE180 and ECSE180 Installation Instruction MM.5004

Centerline of Unit

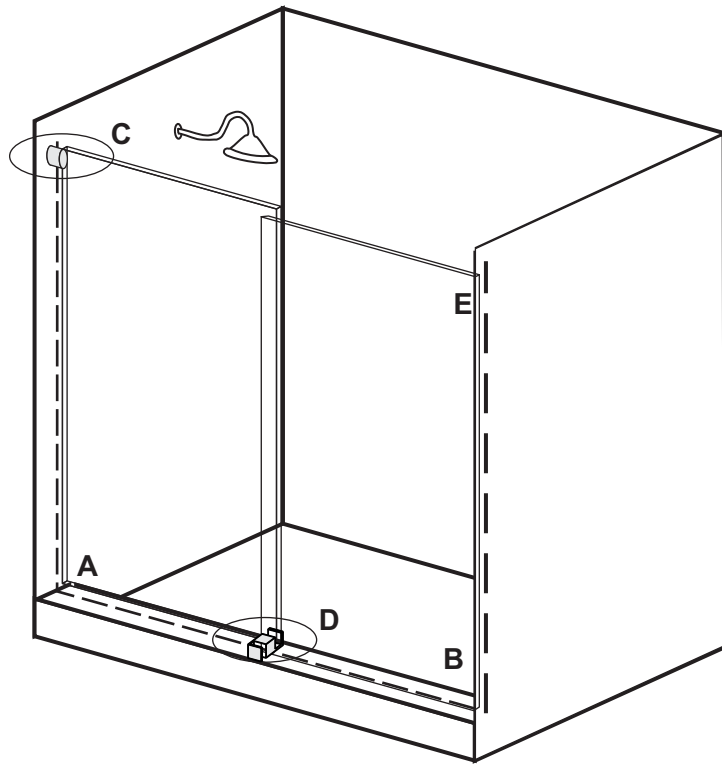
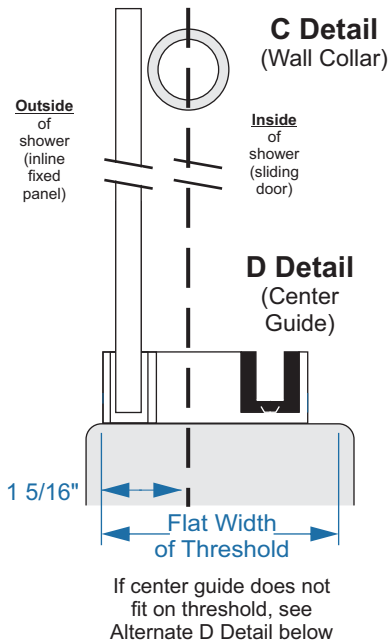

Threshold Centerline (A to B)

- The "flat width" of the threshold does not including rounded edges
- Measure 1 5/16" front to back of the flat to locate the Centerline of the unit. Draw this line from A to B.

Vertical Centerline (A to C)

- Using a level, extend the Threshold Centerline vertically up both walls
- Note the Wall Collar is installed on this centerline (Detail D)

Center Guide (Detail D)

- The center guide will extend approximately 1 5/16" in front of the Threshold Centerline (A to B). This can deviate somewhat due to adjustments made during installation.
- **Alternate D Detail:** If the "flat" is less than approximately 2 3/4", the center guide may hang over the back. This is common for many molded shower pans. It can prohibit you from using a screw and anchor to secure the center guide. Use high quality VHB tape and silicone to secure the center guide as shown to the right. High strength 5 minute epoxy can be used to secure the black door silencer/guide into the base.

B Detail (Top view of Wall Connection)

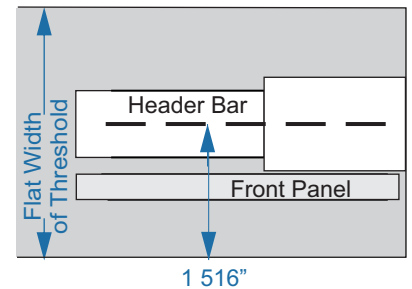

How to Measure:

- To provide proper Front Opening dimension, measure from A to B. Use a level to check conditions. There should be no more than 1/4" deviation from A to B
- Return Panel dimension is B to E. There should be no more than 1/4" deviation from B to E
- Measure the desired or standard height of your unit along A to B.

Alternate D Detail (Center Guide)

