

Installation Instructions for

ASD

1/4" Swing Door

FIRST STEPS - Identify the model number of your unit.

- Look on the white shipping label on the outer cardboard box.
- **Model number** on label should correspond to one listed above.

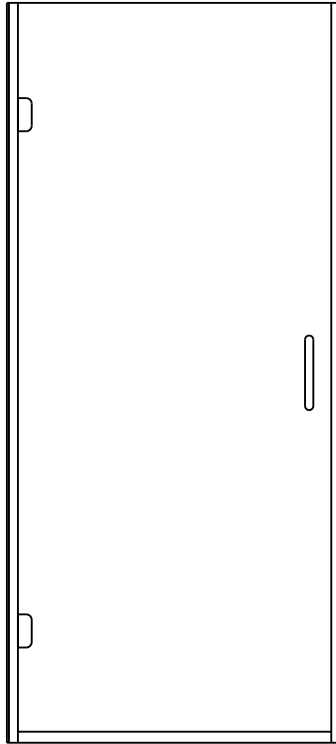

ASD

NOTE:

- Installation procedures are the same for tub or shower height units
- The images in this manual show an arrangement with the showerhead to the left. The same instructions apply for the opposite orientation where the examples would be reversed.

Required Tools

* Pencil or water soluble felt pen

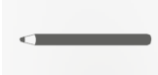

* Hacksaw with 24 tooth blade

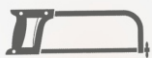

* Metal file (smooth sharp edges)

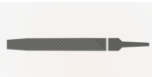

* Tape measure



* Clear 100% Silicone (recommended)



* #2 Phillips Screw driver



* 1/8", 3/16", 1/4", 3/8" drill bits (carbide for tile)



* Caulking gun



* Drill, electric or battery



* 4 ft. Level



* Rubber mallet



* Razor knife



P/N MM.5060
rev061920

READ ENTIRE MANUAL BEFORE INSTALLATION AND OPERATION

Warnings and General Shower Door Information



**SAFETY
WARNINGS:**



READ AND FOLLOW INSTRUCTIONS: Failure to follow all instructions, warnings and guidelines may result in serious injury or death, may cause water damage, and will void the terms of your warranty.

General Safety and Installation Policies

Before Installation:

- **Proper Size:** Ensure the enclosure is the proper size for your opening prior to beginning installation.
- **Safe Installation:** Some units may require two or more people to safely install the enclosure properly.
- **Packaging:** It is recommended to retain all packaging and other materials until installation is complete in the event of a return.
- **Inspect:** Installer should inventory all parts or components and inspect them for damage prior to beginning installation.
- **Sharp Edges:** Exposed ends of aluminum and other hard components can be rough, sharp or jagged due to the processes of cutting, drilling, notching, etc. Sharp ends must be deburred, smoothed or rounded by the installer before installation.
- **Safety equipment and tools:** Have all necessary safety equipment (glasses and gloves) and proper tools for the installation. The installer is responsible for determining the correct drill bit(s) for the installation.
- **New Tile:** We recommend that you allow at least 2 days (48 hours) for the tile cement and grout to dry before installing enclosure.

During Installation



- **Proper backing:** Shower doors are heavy. Therefore, glazing channels, fillers, hinges and headers blocks (structural components) should be secured to studs or solid backing beneath the tile or decorative substrate. Fasteners should screw directly into the backing. Wall anchors are provided primarily to separate screws from tile to reduce the possibility of cracking.

- **Tempered glass:** Glass can break. Shower door panels are tempered to ASTM C1048 specifications as required by building codes. Glass is tempered to greatly increase its strength and to make it fragment into smaller and lighter pieces reducing the possibility of injury in the event that the glass does break. Tempered glass will break and may cause bodily injury if you attempt to cut, drill, mill or alter it in any way. Care must be taken when handling tempered glass. Pay special attention to protect all edges of the glass from contact with hard surfaces.
- **Horizontal surfaces and installation holes:** Avoid drilling into the horizontal surfaces of tubs or showers unless it is required for the structural integrity of the unit. If you drill into horizontal surfaces, always generously caulk the holes, anchors, screws and on top of the screw head. If this is not done, or is done improperly, water damage can occur under the tile or substrate.
- **Weep holes in horizontal channels:** Drilling 3/8" weep holes on the inside of horizontal channels is recommended to allow any moisture build-up inside a channel to exit the channel. Due to varying installation conditions and installer's/owner's personal preference, however, we do not drill them in the factory.
- **Sliding and swinging glass doors:** A door may be improperly installed if it hits or scrapes against bathroom obstructions (toilets or cabinets) or any metal or glass components of the shower door itself. This could lead to glass breakage or serious injury. The installer must correct the deficiencies before allowing the door to be used.
- **Surface conditions:** Most shower door designs allow for out-of-square or unlevel installation. Generally, any outage more than 3/8" that was not identified during the ordering process is outside of these allowances and can result in an improper installation.

Caulking/Siliconing the Unit:

- Always clean all contact surfaces before caulking and use a high grade 100% silicone for best results.
- After installation, at a minimum, caulk the entire outside perimeter of the unit where the unit touches walls, sills, and step-ups, etc. Also caulk any vertical joints between metal components where water build-up inside of the channels could leak out.

After Installation:

- **Curing times:** Adhere to manufacturers' recommended curing times for VHB tapes, silicones and any other adhesives, coatings or chemicals used during installation. Unless otherwise stated, it is recommended to wait 72 hours before using the enclosure.
- **Normal wear and tear:** Although these enclosures are designed to last for years, certain items (such as the polycarbonate seals and door sweeps) may need to be replaced as they show signs of aging and wear.

General Disclaimers

- **Shower Doors are not watertight:** Consumers should understand that a shower door is not watertight. The amount of water that can escape your shower can vary greatly based on shower/tub size, configuration of shower head(s), type of thresholds and drains and by the type of shower door itself. Heavy glass units with no or limited vinyl seals, for example, can allow water to escape under normal conditions. Doors with more metal and seals generally provide more water protection. Excessive water pressure or directing shower heads or hand held sprays directly at doors or joints is not a normal shower conditions and can result in leaks.
- **Towel bars, handles and accessories** are in no way considered to be grab bars or other bracing or fall prevention mechanisms. The intent of these accessories is to facilitate proper operation or enhance the esthetics and functionality of the unit.

Owners Manual:

Refer to your Owners Manual for general installation and cleaning and care instructions. If a copy of the Owners Manual was not included, you can download one on the RESOURCES page of our website.

Questions or Comments:

1-800-843-3332

Installation Instructions

Model: ASD - Accent Swing Door

1/4" Frameless Door



P/N MM.5060 (9-18)

This Installation Instruction is a component of the latch pack.

FIG. #1 - Accent Shower Door Assembly

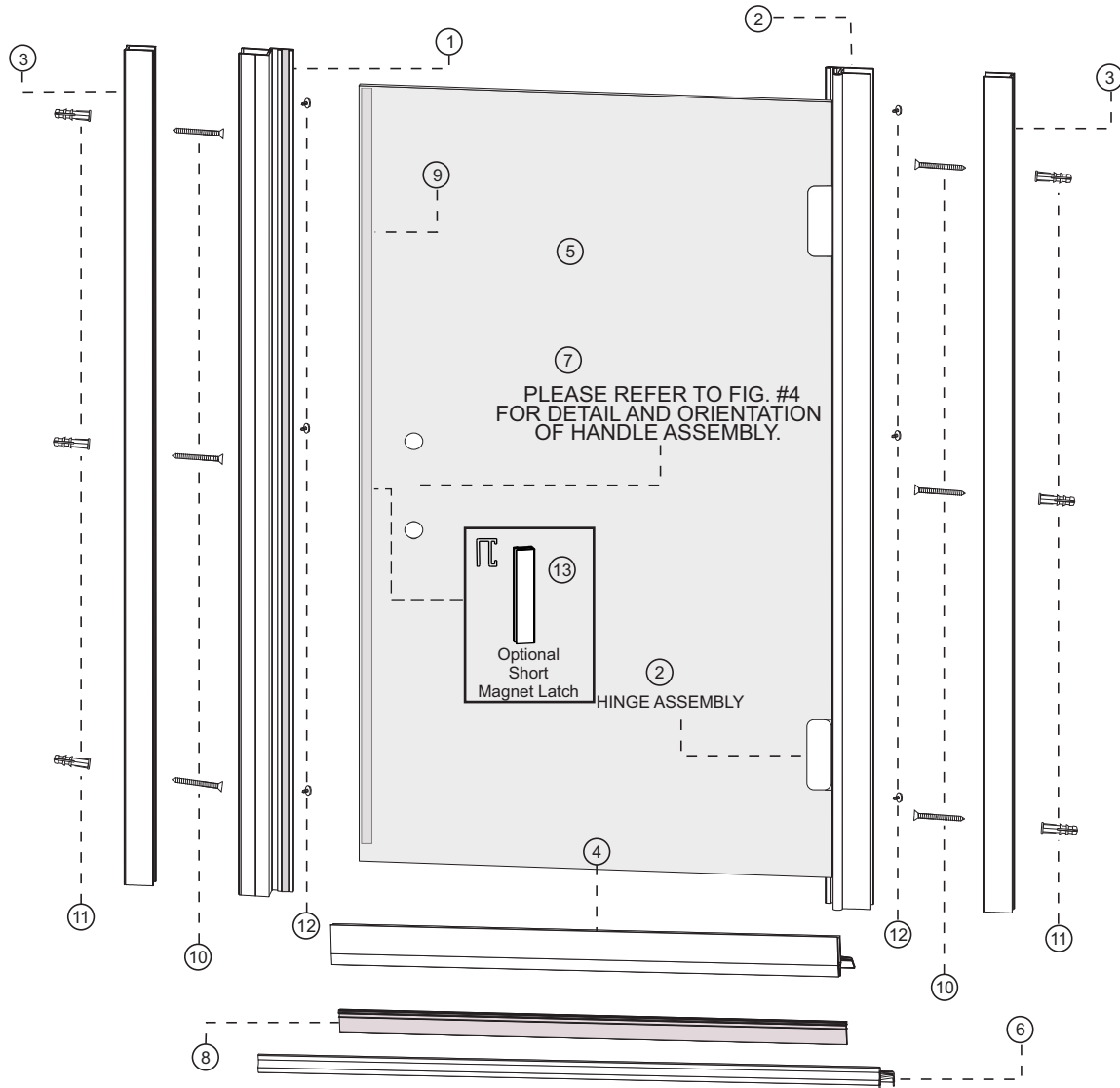

Parts List

ITEM #	PART#.	DESCRIPTION	QTY.	ITEM #	PART#.	DESCRIPTION	QTY.
1	1005	Latch Jamb	1	4	1009	Drip Deflector	1
	VN.4100	Latch Magnet	1		5		Glass Door Panel
2		Hinge Jamb	1	6	1019	Dam Strip (optional)	1
		VS-5 Hinge Vinyl	1	7	Fig. #3	D-Pull Assembly	1
		Hinge	2	8	4018	Vinyl Bottom Sweep	1
		Hinge Pin	2	9	4102	Glass Magnet	1
		Hinge Bushing	4	10	BP.3027	#8 X 1-1/2 FHPHMSMS	6
		Female Fastener	2	11	BP.3027	3/16 Wall Anchors	6
		#6-32X5/16 Truss Head	2	12	BP.3027	#8 X 1/2 TEK Screw	6
3	1003	Jamb Fillers	2	13	BP.3701	Optional Short mag plate	1

SPECIAL NOTE - LEFT OR RIGHT SWING:

The ASD shower door is designed to be installed as a left or right hinged swing door. Therefore, the Jamb Fillers, (ITEM #3), the Hinge Jamb, (ITEM #2), and the Latch Jamb, (ITEM #1), are cut at the factory, approximately 1" longer than is necessary. During the installation you will be instructed when to cut the above components to achieve the flush-at-top appearance. This procedure will give the door a much more finished look. If you do not desire the flush-at-top appearance, all metal can be installed at the factory cut lengths. Leaving the material uncut will not hamper the function of the door. These instructions assume that the above extrusions will be cut flush with the top of the Door Glass Panel.

STEP 1 - LOW CURB DAM STRIP:

Evaluate your threshold. There should be an inward slope of some kind to allow any water that accumulates on the threshold to run back into the shower. If this slope is not present, it is advisable to use the Low Curb Dam Strip, see (FIG. #5), that is included with this product. It is optional. To install, simply cut it to the wall to wall dimension minus 1/16" , place it over the centerline of the shower base, then use several pieces of masking tape to temporarily hold the Low Curb Dam Strip in place. Caulk each end for water protection then follow the remainder of these installation instructions to install the door on top of the Low Curb Dam Strip.

FIG. #2 - Jamb Filler

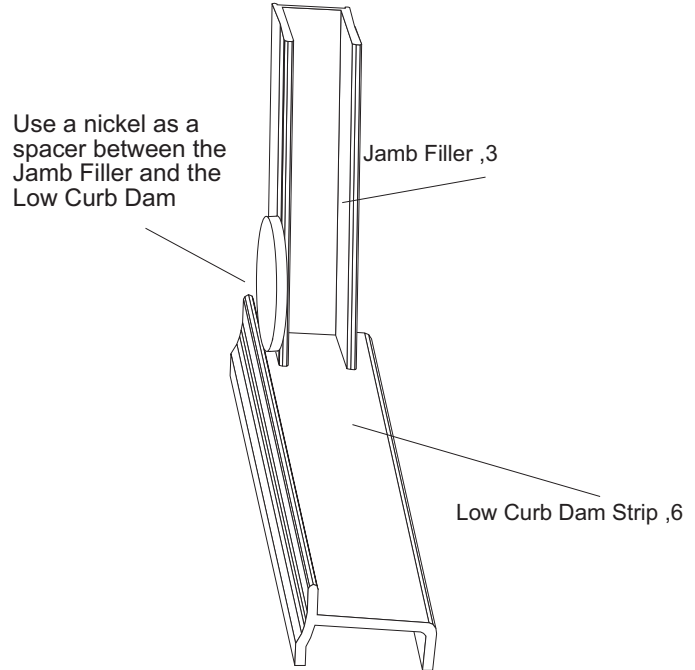
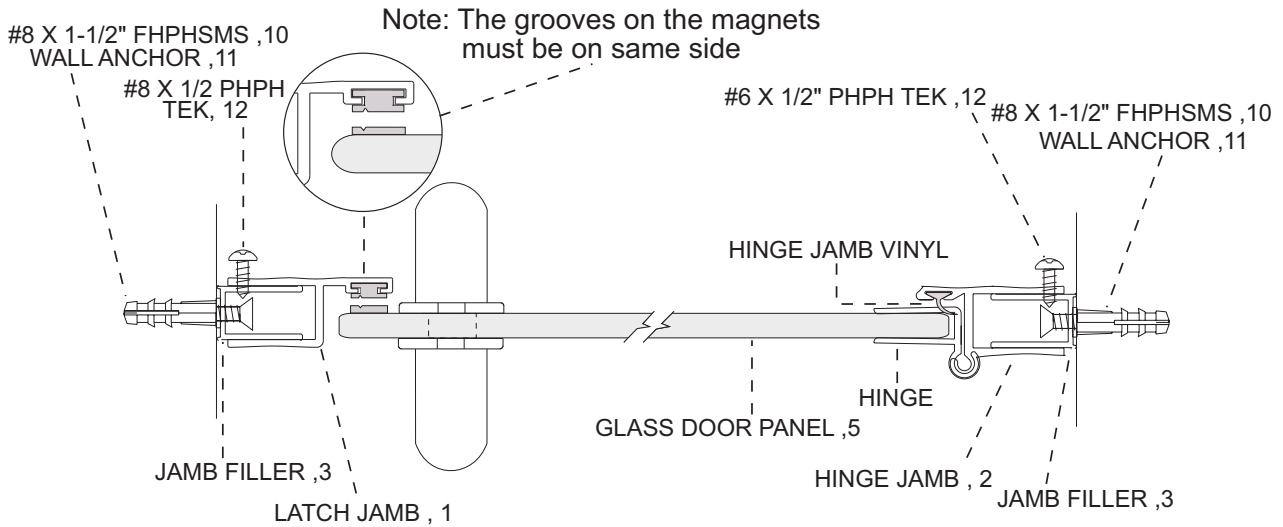

FIG. #3 - Shower Door Assembly - Top View



These installation instructions must be followed to ensure proper operation of the door and to reduce the risk of serious injury. Any deviation from these instructions can result in a serious safety hazard

All exposed ends of aluminum that are rough, sharp or jagged due to the metal being cut, drilled or damaged should deburred, smoothed or rounded by the installer before installation. Failure to do so could result in serious injury to the user of the enclosure.

Any part of the swinging glass door hitting any unprotected bathroom obstruction or metal or glass component of the shower door itself, may indicate improper installation and could lead to serious injury. Installer must correct the deficiencies before allowing the door to be used.

STEP 2 - JAMB FILLERS:

Determine the direction your door will swing and using a hacksaw, cut the Hinge Jamb (ITEM #2) flush with the top edge of the glass. Take one of the Jamb Fillers (ITEM #3) and cut it to the same length as the Hinge Jamb in place on the Low Curb Dam Strip or the shower base at the wall that will hold the Hinge Jamb. If you are using the Low Curb Dam Strip, place a spacer between the Jamb Filler and the lip of the Low Curb Dam Strip (FIG. # 2). This will become very important later in the installation. Plumb the Jamb Filler with a level, then, using the factory installation holes as a template, mark the hole locations onto the wall. Use a pencil or a water soluble marker. Next, drill the three holes using a 3/16" drill bit. (Use a carbide tipped bit and water if going into tile or other types of masonry material). Insert three Wall Anchors, (ITEM #11), into the holes then re-align the Jamb Filler with the holes. Secure with three #8 X 1-1/2" FHPHMS screws (ITEM #10). Set the second Jamb Filler in place at the opposite end of the Low Curb Dam Strip or the shower base (remember to use the spacer as before). Plumb it with a level, then, mark only the bottom hole and drill with a 3/16" drill bit. Insert one Wall Anchor, then secure with one #8 X 1-1/2" FHPHMS screw. Leaving the top two holes unsecured will aid in the final adjustment later on. At this point, one of the Jamb Fillers on the wall will be 1" taller than the other. This is necessary for final adjustment later.

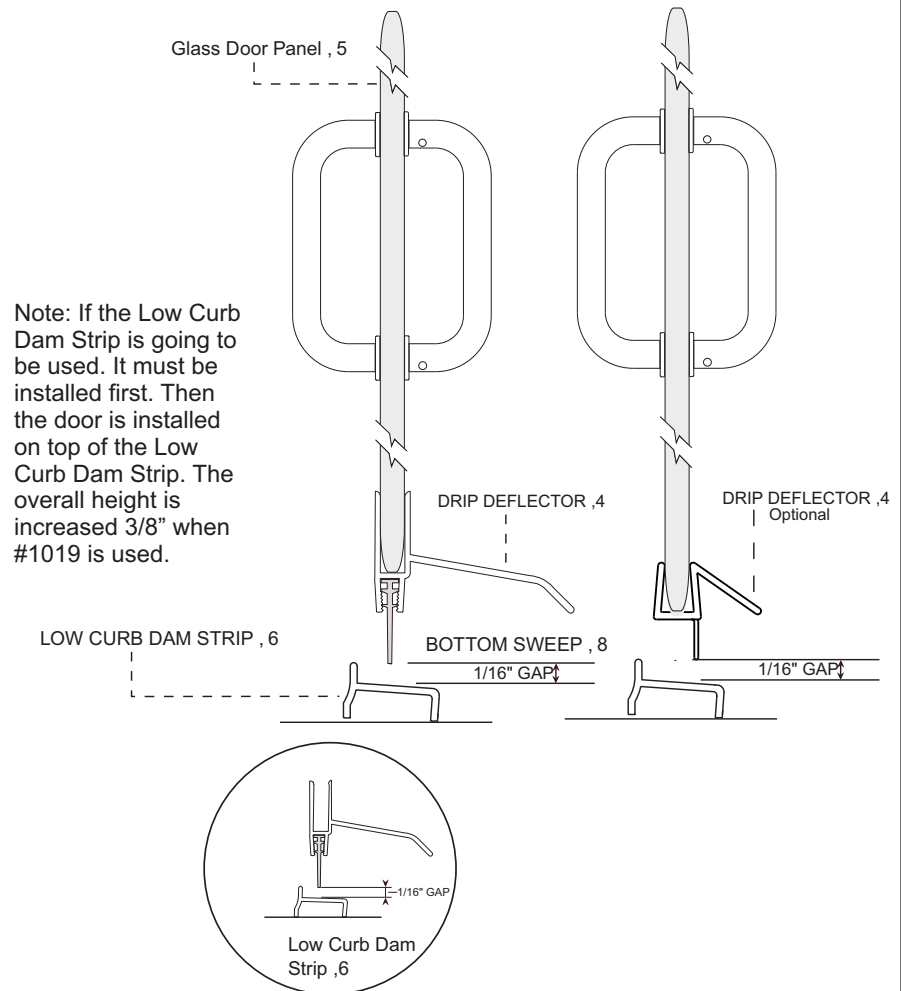
Fig. #5 - Bottom Sweep Gap Clearance

Note: If the Low Curb Dam Strip is going to be used. It must be installed first. Then the door is installed on top of the Low Curb Dam Strip. The overall height is increased 3/8" when #1019 is used.

Note: A 1/16" gap clearance is required between the vinyl Bottom Sweep strip and the Low Curb Dam Strip so that water may drain under sweep, back into shower.

STEP 3 - DRIP DEFLECTOR AND SWEEP:

Take the vinyl Bottom Door Sweep, (ITEM #8), and slide it into the bottom of the Drip Deflector as shown in (FIG. #5). Trim the vinyl leaving 1/4" of the Door Sweep protruding from each end. Turn the door assembly upside down (bottom up) on a cushion or pad. Set the Drip Deflector, (ITEM #4), over the bottom edge of the door with the deflector portion to the inside of the shower. With a mallet or block of wood, gently tap the deflector over the edge of the door panel as far as it will go. In most cases, the glass thickness is enough to hold the Drip Deflector in place for the life of the door. In some cases, the corners of the Deflector may be "pinched" to hold the Deflector in place, or simply inject a small amount of caulking into the channel where the glass will fit to maximize the holding power of the Deflector. NOTE: Only a small amount of caulking is necessary, too much caulking will be squeezed out during adjustment. For the optional plastic deflector, measure the width of the glass and cut the deflector to this length. Notch both ends so that the door can close all the way.

STEP 4 - DOOR ASSEMBLY:

NOTE: The ASD door is designed to have 1" of outward adjustment in width. EXAMPLE: An ASD-24 door will fit a net opening of 24" tight up to 25". Adjustment should be made by adjusting the Hinge Jamb first, then the Latch Jamb. Slide the door assembly over the appropriate Jamb Filler and move it into place. Use a small level placed along the top horizontal edge of the glass to level the door. From the inside of the shower, Secure the top hole with one #8 X 1/2" PHPH TEK screw (ITEM #12). The door will hold in place with only the top screw installed. Next, re-level the door and drill through the middle and bottom holes with a #32 wire gauge drill bit. then secure the door with two #8 X 1/2" PHPH TEK screws (ITEM #12).

STEP 5 - FINAL ADJUSTMENT:

Slide the Latch Jamb (ITEM#1), with the allure magnet installed over the unsecured Jamb Filler. The bottom of the Latch Jamb may be crimped to keep the magnet from sliding out. Standing in front of the door, close the shower door against the Latch Jamb and Jamb Filler. Check to see if the the glass shower door closes flush against the Latch Jamb and Jam Filler. If the glass is hitting the top or bottom of the Latch Jamb first, then the door needs to be adjusted. To correct this problem, adjust the Latch Jamb (inside to outside) by pivoting on the bottom screw, until the glass door seals against the full length of the Latch Jamb at the same time. Mark this location on the wall. While holding the Latch Jamb in position, mark where the top edge of the door panel hits the latch, this is the length you will cut the Latch Jamb and Jamb Filler flush with the top of the door panel. Remove the Latch Jamb and Jamb Filler and cut both to the same length using the mark made on the Latch Jamb. **SPECIAL NOTE:** Be sure to cut the filler to length off what will be the top end of the piece, so it will still line up with the holes already drilled in the wall. Reposition the Jamb Filler to the vertical mark made earlier. Hold in position and mark the remaining two holes. Drill and Secure the Jamb Filler.

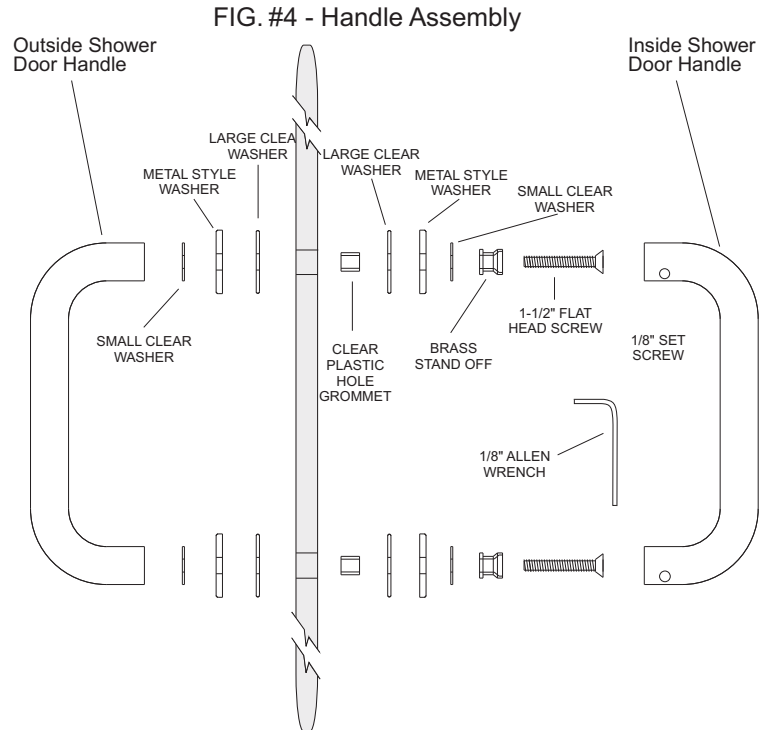
**STEP 6 - LATCH JAMB:**

Slide the Latch Jamb, (ITEM#1), over the now secured Jamb Filler. There is a indexing groove lengthwise in the magnet. Apply the second magnet to the glass shower door panel by orienting the groove on door magnet so that when the door is closed, the magnet grooves mirror image each other (See Fig. #3). Peel the backing from the magnet and apply down the inside of the latch side edge of the glass shower door panel. Trim the magnet flush at the top of the glass and the top of the Drip deflector. Close the shower door and adjust the Latch Jamb so the latch jamb and glass magnets line up and achieve maximum magnetic closure. Once the shower door sits flush and plumb. The final step is to secure the shower door to the walls by installing 3 - #8 X 1/2 PHPH TEK (ITEM#12) screws through the three factory holes in the Latch Jamb into the Jamb Filler.

STEP 7 - HANDLE ASSEMBLY:

The shower door handles come preassembled. In order to install the handles onto the shower door, the handles will need to be disassemble by using the provided 1/8" Allen Wrench. Remove the inside handle. The handle parts are in their proper order out of the box and will reassemble this way onto the glass. For reference, Fig.#4 shows the proper order of the handle hardware parts . **WARNING: THIS SHOWER DOOR HANDLE SHOULD NOT BE INSTALLED WITHOUT THE CLEAR PLASTIC HOLE GROMMETS.** The plastic grommets prevent the glass from touching the metal screws. If they come in contact the with the glass, the glass can break and create a serious safety hazard.

STEP 8 - DRIP DEFLECTOR:

Finish the installation by adjusting the drip deflector as follows: Close the door and from the outside, use a block of wood to tap the deflector down so that the Door Sweep is approximately 1/16" above Low Curb Dam Strip of the shower base. The deflector does not need to be tilted to function.

STEP 9 -CAULKING:

First, seal each end of the drip Deflector with caulk, then run a bead of caulking the full length on the inside of the shower where each Jamb Filler meets the wall and across the bottom if the Low Curb Dam Strip was used.