

Installation Instructions for

1/4" Door Models: **SSE/STE180 or DSE/DTE180**
 3/16" Door Models: **VSE/VSE180 or CSE/CTE180**
 3/16" Framed Models: **FSE/FTE180 or BSE/BTE180**

FIRST STEPS - Identify the model number of your unit.

- Look on the white shipping label on the outer cardboard box.
- **Model number** on label should correspond to one listed above.
 Or look below and identify by **towel bar type and glass thickness**

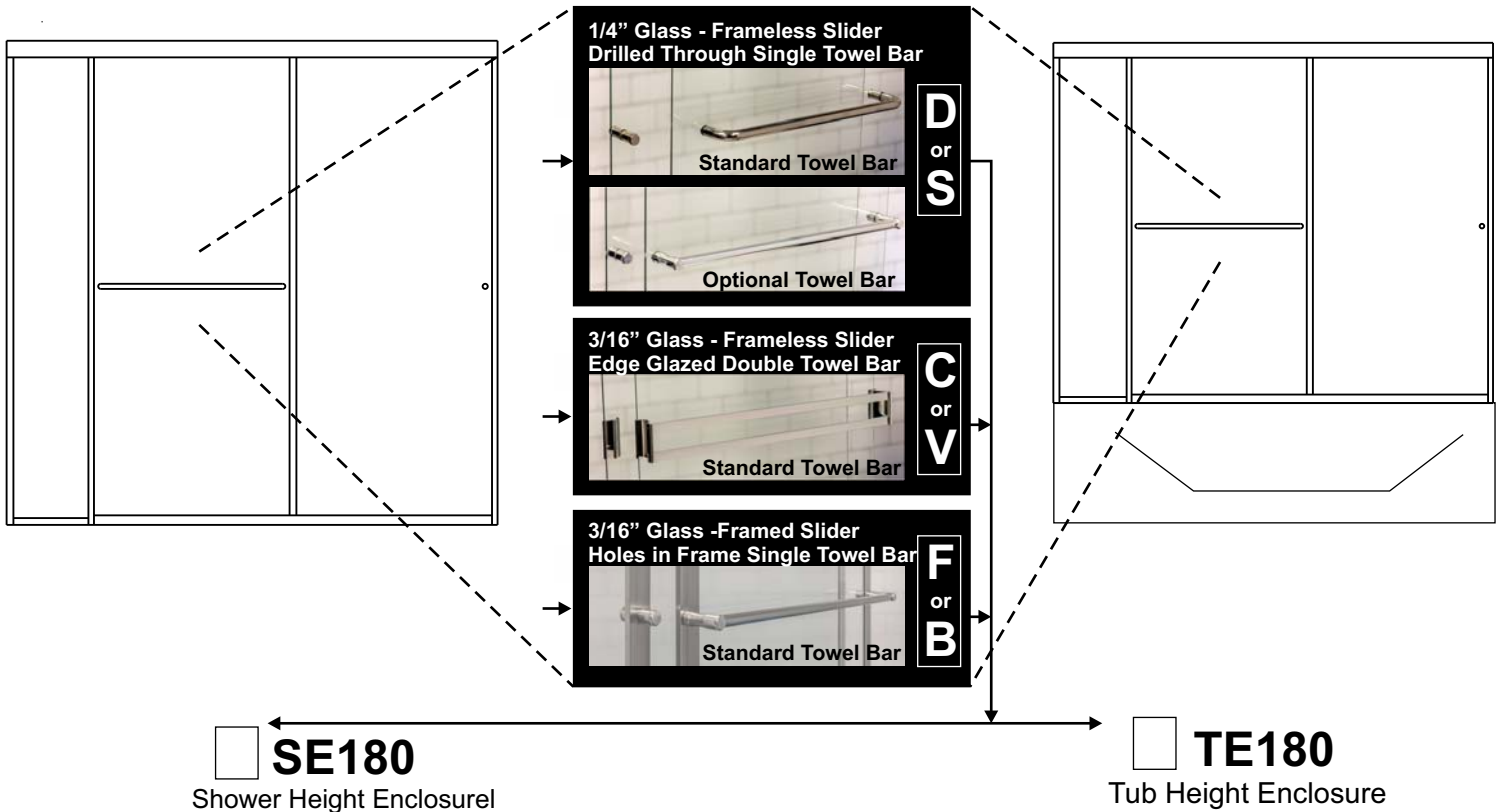

NOTE:

- Installation procedures are the same for tub or shower height units
- The images in this manual show an arrangement with the showerhead to the left. The same instructions apply for the opposite orientation where the examples would be reversed.

Required Tools

* Pencil or water soluble felt pen

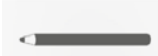

* Hacksaw with 24 tooth blade



* Metal file (smooth sharp edges)



* Tape measure



* Clear 100% Silicone (recommended)



* #2 Phillips Screw driver



* 1/8", 3/16", 1/4", bits (carbide for tile)



* Caulking gun



* Drill, electric or battery



* 4 ft. Level



* Rubber mallet



* Razor knife



P/N MM.5038
rev030121

READ ENTIRE MANUAL BEFORE INSTALLATION AND OPERATION

Warnings and General Shower Door Information



**SAFETY
WARNINGS:**



READ AND FOLLOW INSTRUCTIONS: Failure to follow all instructions, warnings and guidelines may result in serious injury or death, may cause water damage, and will void the terms of your warranty.

General Safety and Installation Policies

Before Installation:

- **Proper Size:** Ensure the enclosure is the proper size for your opening prior to beginning installation.
- **Safe Installation:** Some units may require two or more people to safely install the enclosure properly.
- **Packaging:** It is recommended to retain all packaging and other materials until installation is complete in the event of a return.
- **Inspect:** Installer should inventory all parts or components and inspect them for damage prior to beginning installation.
- **Sharp Edges:** Exposed ends of aluminum and other hard components can be rough, sharp or jagged due to the processes of cutting, drilling, notching, etc. Sharp ends must be deburred, smoothed or rounded by the installer before installation.
- **Safety equipment and tools:** Have all necessary safety equipment (glasses and gloves) and proper tools for the installation. The installer is responsible for determining the correct drill bit(s) for the installation.
- **New Tile:** We recommend that you allow at least 2 days (48 hours) for the tile cement and grout to dry before installing enclosure.

During Installation



- **Proper backing:** Shower doors are heavy. Therefore, glazing channels, fillers, hinges and headers blocks (structural components) should be secured to studs or solid backing beneath the tile or decorative substrate. Fasteners should screw directly into the backing. Wall anchors are provided primarily to separate screws from tile to reduce the possibility of cracking.

- **Tempered glass:** Glass can break. Shower door panels are tempered to ASTM C1048 specifications as required by building codes. Glass is tempered to greatly increase its strength and to make it fragment into smaller and lighter pieces reducing the possibility of injury in the event that the glass does break. Tempered glass will break and may cause bodily injury if you attempt to cut, drill, mill or alter it in any way. Care must be taken when handling tempered glass. Pay special attention to protect all edges of the glass from contact with hard surfaces.
- **Horizontal surfaces and installation holes:** Avoid drilling into the horizontal surfaces of tubs or showers unless it is required for the structural integrity of the unit. If you drill into horizontal surfaces, always generously caulk the holes, anchors, screws and on top of the screw head. If this is not done, or is done improperly, water damage can occur under the tile or substrate.
- **Weep holes in horizontal channels:** Drilling 3/8" weep holes on the inside of horizontal channels is recommended to allow any moisture build-up inside a channel to exit the channel. Due to varying installation conditions and installer's/owner's personal preference, however, we do not drill them in the factory.
- **Sliding and swinging glass doors:** A door may be improperly installed if it hits or scrapes against bathroom obstructions (toilets or cabinets) or any metal or glass components of the shower door itself. This could lead to glass breakage or serious injury. The installer must correct the deficiencies before allowing the door to be used.
- **Surface conditions:** Most shower door designs allow for out-of-square or unlevel installation. Generally, any outage more than 3/8" that was not identified during the ordering process is outside of these allowances and can result in an improper installation.

Caulking/Siliconing the Unit:

- Always clean all contact surfaces before caulking and use a high grade 100% silicone for best results.
- After installation, at a minimum, caulk the entire outside perimeter of the unit where the unit touches walls, sills, and step-ups, etc. Also caulk any vertical joints between metal components where water build-up inside of the channels could leak out.

After Installation:

- **Curing times:** Adhere to manufacturers' recommended curing times for VHB tapes, silicones and any other adhesives, coatings or chemicals used during installation. Unless otherwise stated, it is recommended to wait 72 hours before using the enclosure.
- **Normal wear and tear:** Although these enclosures are designed to last for years, certain items (such as the polycarbonate seals and door sweeps) may need to be replaced as they show signs of aging and wear.

General Disclaimers

- **Shower Doors are not watertight:** Consumers should understand that a shower door is not watertight. The amount of water that can escape your shower can vary greatly based on shower/tub size, configuration of shower head(s), type of thresholds and drains and by the type of shower door itself. Heavy glass units with no or limited vinyl seals, for example, can allow water to escape under normal conditions. Doors with more metal and seals generally provide more water protection. Excessive water pressure or directing shower heads or hand held sprays directly at doors or joints is not a normal shower conditions and can result in leaks.
- **Towel bars, handles and accessories** are in no way considered to be grab bars or other bracing or fall prevention mechanisms. The intent of these accessories is to facilitate proper operation or enhance the esthetics and functionality of the unit.

Owners Manual:

Refer to your Owners Manual for general installation and cleaning and care instructions. If a copy of the Owners Manual was not included, you can download one on the RESOURCES page of our website.

Questions or Comments:

1-800-843-3332

Parts Diagram for DSE, DTE, SSE or STE

(Installation procedure is the same regardless of height of unit)

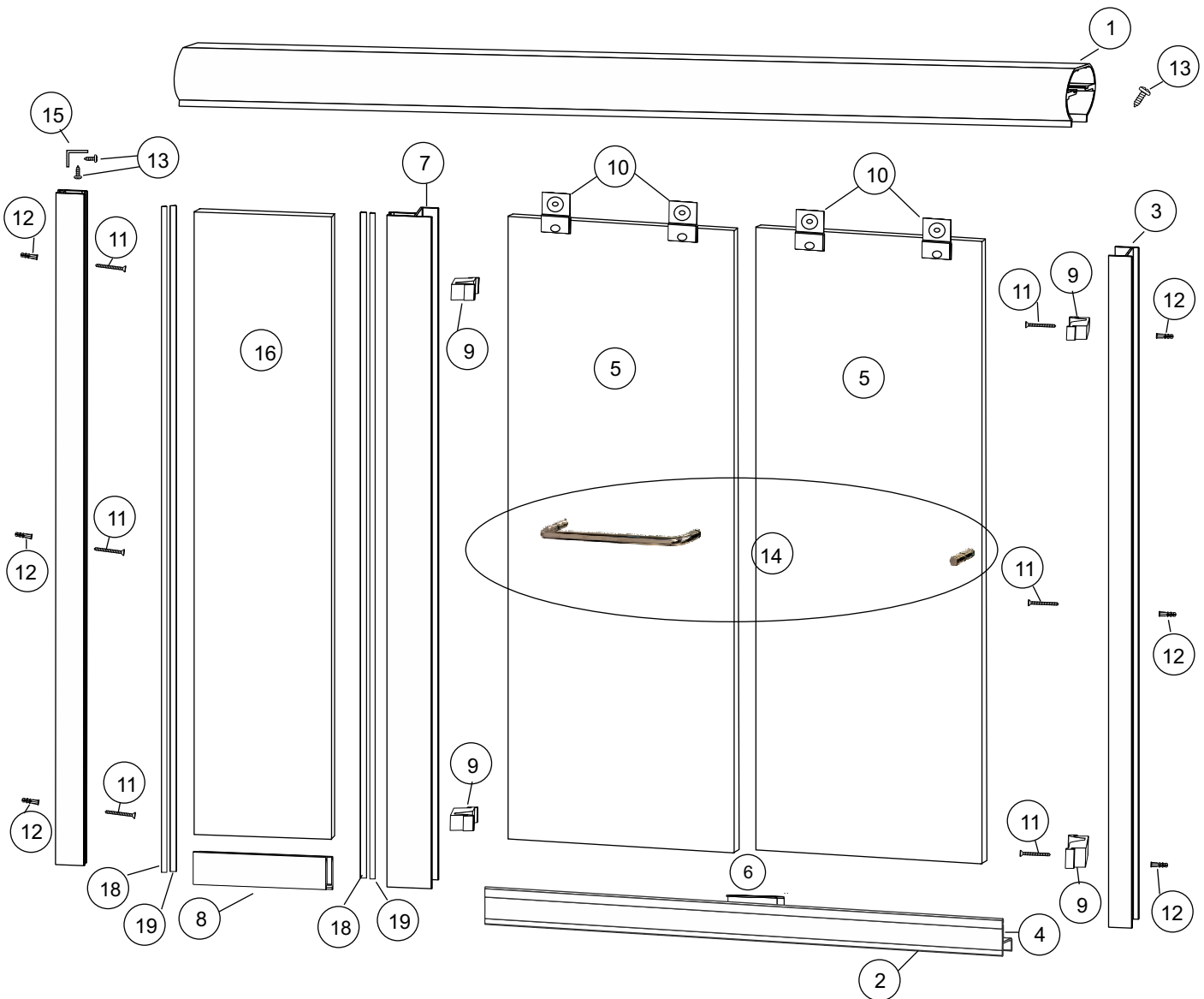

Parts List

Item	Part #	Description	QTY
1	EX.1049	Tub Header	1
2	EX.1062	Stay Clean Sill	1
3	EX.1051	Tub Jamb	2
4	VN.4032	TF-2B T-Fin	1
5		Sliding Glass Panel	2
6	BP.3541	AVG-3 Center Guide	1
7	EX.1159	180 Tub Post	1
8	EX.1070	Panel Sill	1

Item	Part #	Description	QTY
9	BP.3541	Bumper Guides	4
10	SP.2256	Hanger Bracket Assy	4
11	BP.3136	#8 x 1-1/2 FHPHSMS	6
12	BP.3136	Wall Anchor	6
13	BP.3136	#6 x 3/8 PHPHMS	3
14	HA.27XX	Towel Bar/Screw Kit	1
15	BP.3136	Header Support Clp	1
16		180 Fixed panel	1
17	BP.3000	Anti jump Bag	1

Item	Part #	Description	QTY
18	VN.4031	Glazing Vinyl	2
19	VN.4033	Glazing Vinyl	2

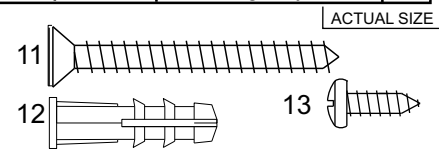

Extra screws may be provided for your convenience



Optional Parts



Optional Towel Bar - BP.3214

Optional Towel Bar BP.3214 (at left) installation steps are on page 8

Parts Diagram for CSE, CTE, VSE or VTE

(Installation procedure is the same regardless of height of unit)

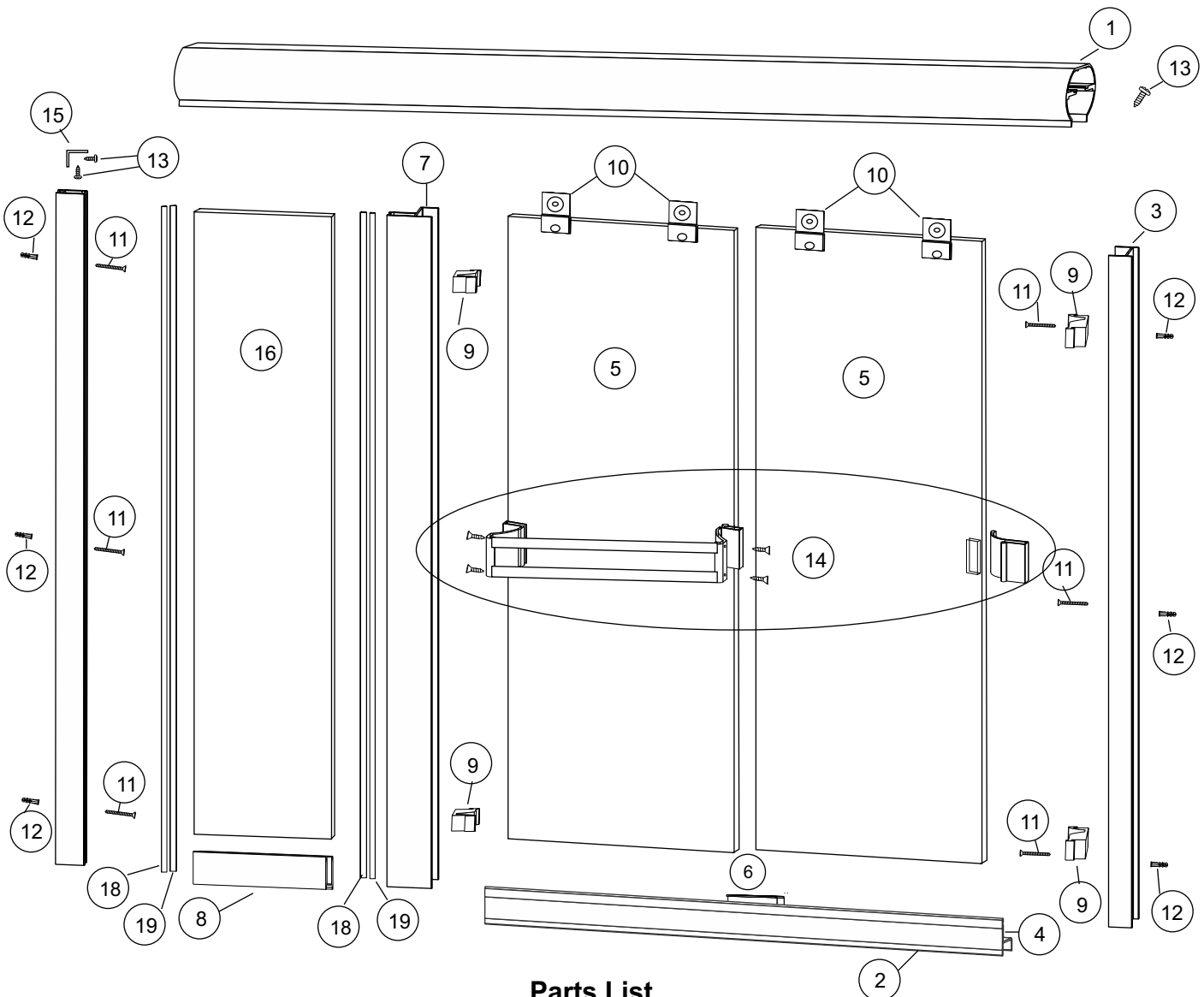

Parts List

Item	Part#	Description	QTY
1	EX.1049	Tube Header	1
2	EX.1062	Stay Clean Sill	1
3	EX.1051	Tube Jamb	2
4	VN.4032	TF-2B T-Fin	1
5		Sliding Glass Panel	2
6	BP.3541	AVG-3 Center Guide	1
7	EX.1159	180 Tub Post	1
8	EX.1070	Panel Sill	1

Item	Part#	Description	QTY
9	BP.3541	Bumper Guides	4
10	SP.2256	Hanger Bracket Assy	4
11	BP.3027	#8 x 1-1/2 FHPHSMS	6
12	BP.3027	Wall Anchor	6
13	BP.3027	#6 x 3/8 PHPHSMS	3
14	HA.27XX	Towel Bar/Screw Kit	1
15		Header Support Clp	1
16		180 Fix panel	1
17	BP.3000	Anti jump Bag	1

Item	Part#	Description	QTY
18	VN.4031	Glazing Vinyl	2
19	VN.4033	Glazing Vinyl	2

ACTUAL SIZE

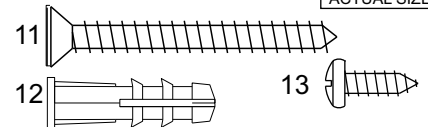

Extra screws may be provided for your convenience



Optional Parts

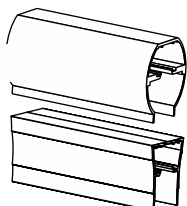

EX.1049 Tub Header (at left) is standard on CSE and CTE and optional on VSE and VTE

EX.1040 Tub Header (at left) is standard on VSE and VTE and optional on CSE and CTE

Parts Diagram for BSE, FTE, BSE or FTE

(Installation procedure is the same regardless of height of unit)

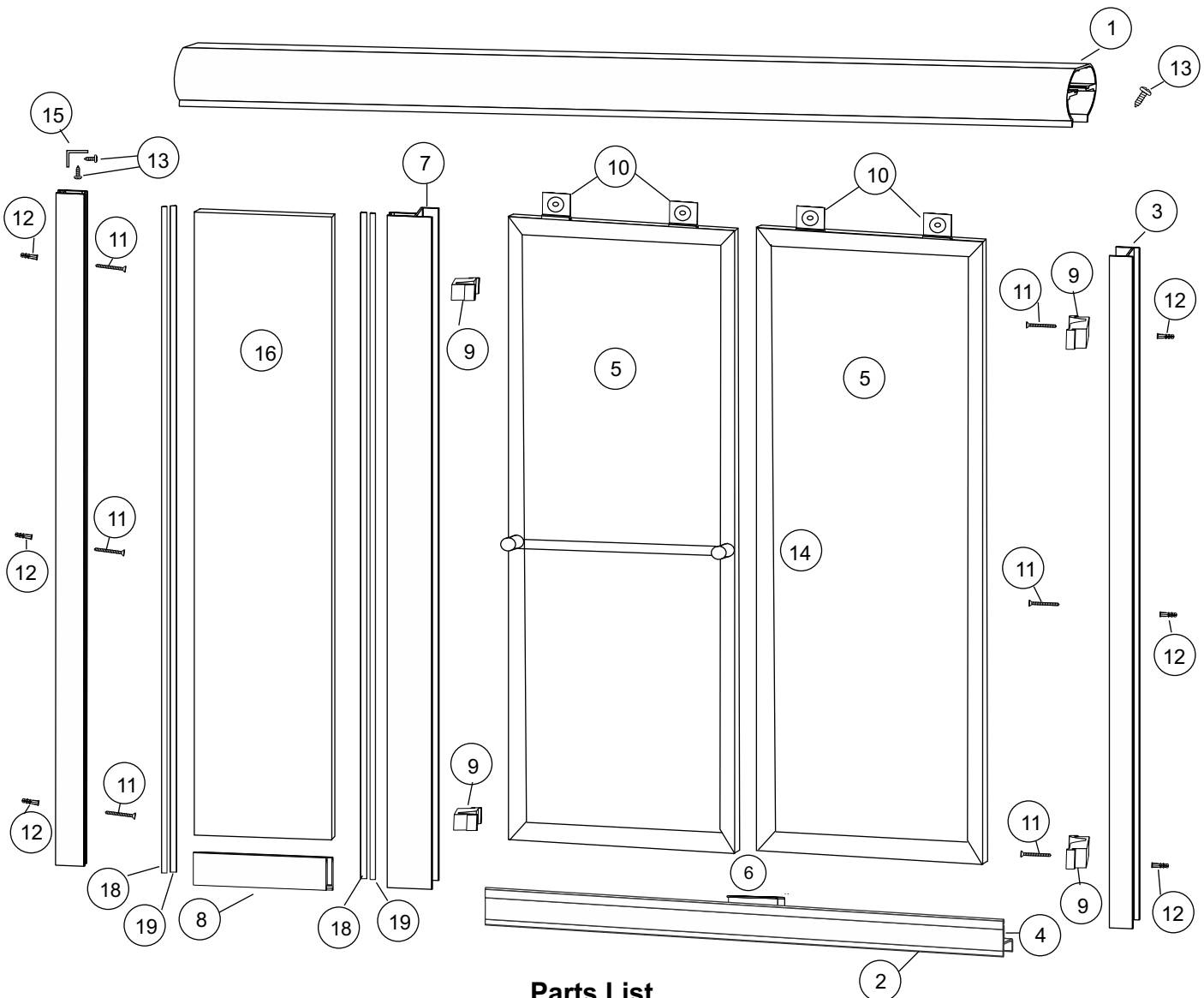

Parts List

Item	Part#	Description	QTY
1	EX.1049	Tub Header	1
2	EX.1062	Stay Clean Sill	1
3	EX.1051	Tub Jamb	2
4	VN.4032	TF-2B T-Fin	1
5		Sliding Glass Panel	2
6	BP.3541	AVG-3 Center Guide	1
7	EX.1159	180 Tub Post	1
8	EX.1070	Panel Sill	1

Item	Part#	Description	QTY
9	BP.3541	Bumper Guides	4
10	SP.2256	Hanger Bracket Assy	4
11	BP.3027	#8 x 1-1/2 FHPHSMS	6
12	BP.3027	Wall Anchor	6
13	BP.3027	#6 x 3/8 PHPHSMS	3
14	HA.27XX	Towel Bar/Screw Kit	1
15		Header Support Clp	1
16		180 Fix panel	1
17	BP.3000	Anti jump Bag	1

Item	Part#	Description	QTY
18	VN.4031	Glazing Vinyl	2
19	VN.4033	Glazing Vinyl	2

ACTUAL SIZE

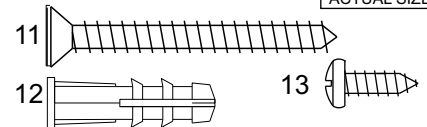

Extra screws may be provided for your convenience



Optional Parts

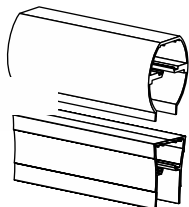

EX.1049 Tub Header (at left) is standard on CSE and CTE and optional on VSE and VTE

EX.1040 Tub Header (at left) is standard on VSE and VTE and optional on CSE and CTE

Installation Instructions

All Models

STEP - 1 Centerline:

Locate the center of the threshold and mark it with a water soluble marker. Please note to the right that the 180 fixed panel sets 7/16" in front of the centerline. Set #15 and #8 Panel sill in place butted into the wall. See exploded view for reference. Use a level and plumb the wall. Mark the holes and drill with a 3/16" drill bit. Use carbide if going into masonry. Insert 3 - wall anchors and secure with 3 - #8 X 1-1/2 PHSMS. insert Panel sill into wall channel and align with sill.

STEP - 2 180 Fixed Panel

Set the #16 fixed panel in place in the panel sill and wall channel, glaze the final edge with the #7 180 Tub Post.

STEP -3 Stay Clean Sill

Measure the distance A, the distance between the tub jambs and deduct 7/16" and cut to size. Drill an 1/8 hole for the center guide. Do not attach center guide at this time. Place the Stay Clean Sill #2 directly over and parallel to the centerline. Hold in place with Painters tape.

STEP - 4 Shower Head Jamb

Install the Tub Jamb #3 opposite the fixed panel wall. With a level, plumb the Tub Jamb and mark only the bottom factory hole location.

Drill the hole with a 3/16 drill bit (Carbide bit for tile) and insert 1 Wall Anchor #12. Insert 1 bumper guide and secure w/ 1 -#8 X 1 1/2 FPHSMS into the bottom hole. Orient bumper guide crevice to the

outside of the shower, tighten until snug.

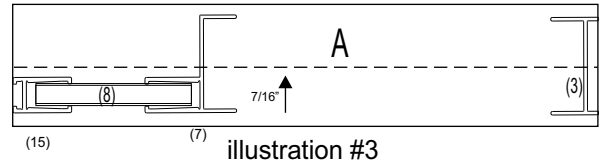
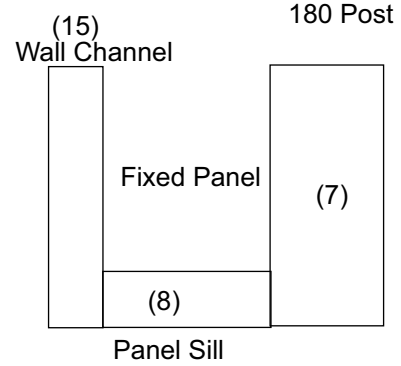

Sill Detail

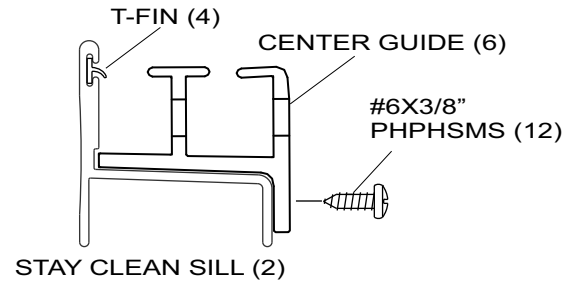

Tub Jamb and Bumper Detail

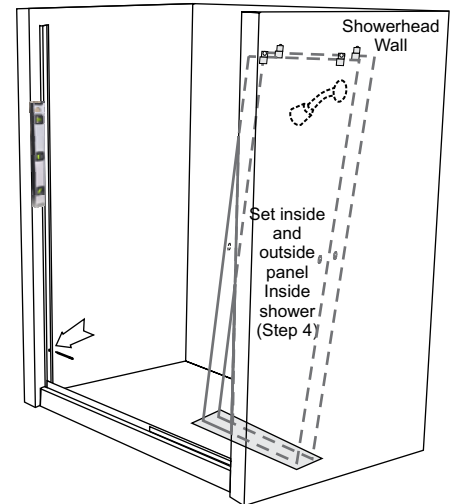

Bumper Guide Orientation Detail for showerhead right →

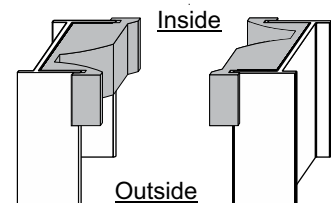

Reverse above orientation for showerhead left

Installation Instructions

All Models

STEP - 5 Tub Header

Deduct 1/16 and cut Tub Header #1 to length. Test fit header

Drill a 1/8" hole at each end on the inside. Screw size is #6 X 3/8 PH #13
Find Parts Bag BP.3000.NTL - Anti-Jump Runners 17 and follow installation instructions

NOTE: Use of runners are encouraged, but optional, and must be ordered separately on some units

Place inside glass panel (Knob Panel) inside the shower or tub stall. Ensure the rollers are facing the wall and knob hole is opposite the shower head. Lean against the back wall. Use pad to protect the glass/tile from damage. Also, place the outside panel, rollers facing out.

- Set header in place over the Tub Jamb but do not secure at this time.

STEP - 6 - Panel Installation:

Make sure that the Tub Jamb opposite the showerhead (only one screw) is snug, and secured with painters tape

Hang outside glass panel (Towel Bar Panel) in place inside the header and slide to showerhead wall (fully secured Tub Jamb)

Install the inside panel and slide to wall opposite shower head

Ensure rollers on both panels are fully seated into the header tracks

Install the Center Guide (6) and securing it with one #6x3/8" MS (13).

STEP - 7- Tub Jamb Adjustment and fastening:

Standing outside the shower, move the sliding panels one at a time into the proper side of unit

Adjust the header side to side (you will have to remove and reapply painter's tape) until both panels pocket perfectly into both Tub Jamb

Mark the remaining two holes of the Tub Jamb onto the wall opposite the showerhead

Slide both panels back to the showerhead Tub Jamb. Remove the Center Guide

Remove both sliding panels and set them in a safe place on a padded surface

Rotate the Tub Jamb out of the way just far enough to reveal the marked holes and drill the holes with a 3/16" drill bit

Insert two Wall Anchors (11)

Re-align Tub Jamb and secure with two #8 X 1-1/2" FHPHMS (10). install the top Bumper Guide (7) with the top screw

Reinstall both of the sliding glass panels as you did earlier in the last step, then reinstall the Center Guide

Tub Header Detail

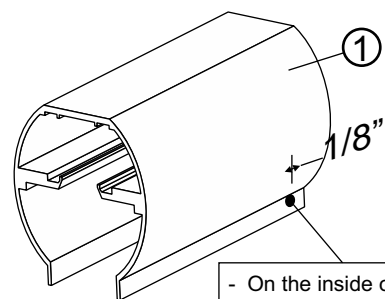

- On the inside of header drill an #32 wire gauge hole into Tub Header (Item #1) 1/8" from end

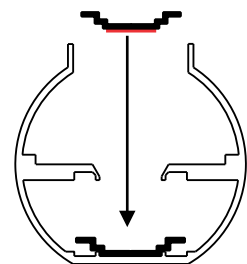

Anti Jump Runner w/ Red Tape installed in EX.1049 Tub Header (same procedure for EX.1040)

Panel Installation Detail

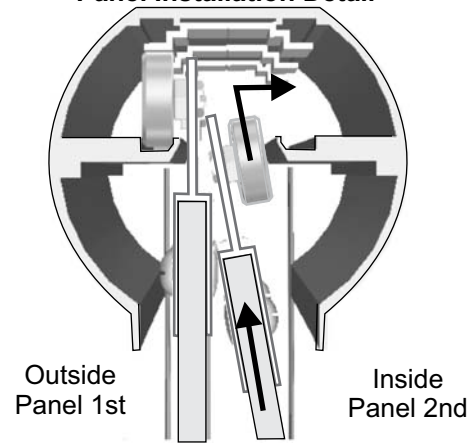

Tub Jamb Adjustment and Fastening Detail

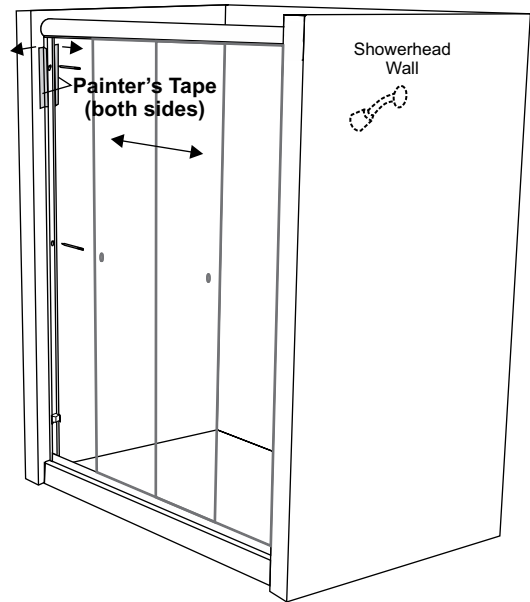

Installation Instructions

All Models

STEP 8 - TOWEL BAR INSTALLATION

See page 9 or refer to the installation instructions provided with your towel bar kit

STEP 9 - PANEL ADJUSTMENT:

To adjust the sliding panels for out-of-square wall conditions or to level them, etc., locate the hex nuts in the Hanger Brackets (10) and the Adjustment Wrench provided in the parts kit.

NOTE: The panels can be adjusted while still hanging in the header.

Loosen the hex nut with the special wrench until roller can slide along the angled slot on the Hanger Bracket (10)
Raise or lower each side of the panel by sliding the roller along the angled slot until desired adjustment is achieved
Be sure to re-tighten the screws.

STEP 9 - HEADER ATTACHMENTS:

Secure the Header to the Tub Jambs by drilling through the holes in the header, from the inside of the shower, into the Tub Jambs with a 1/8" drill bit.

Secure with two #6 X 3/8" PHPHMS (Item #13) as shown in illustration #8.

STEP 11 - SEALANT:

Remove all Painter's Tape used during the installation

Starting at the top of a tub jamb, apply a bead of sealant along the entire outside of the enclosure where it meets the wall and base. End at the top of opposite tub jamb

Additional sealant is needed at the bottom corners where the Tub Jambs meet the Stay Clean Sill:

-Starting from the outside caulk the vertical joint between the tub jamb and sill.

- Move inside the shower and continue to caulk this joint until you finish the run where the vertical joint meetings the threshold on the inside.

- These joints must be totally sealed for a leak proof and structurally secure installation.

NOTE: For optimum results allow the sealant to dry for 24 hours before running the shower.

Panel Adjustment Detail

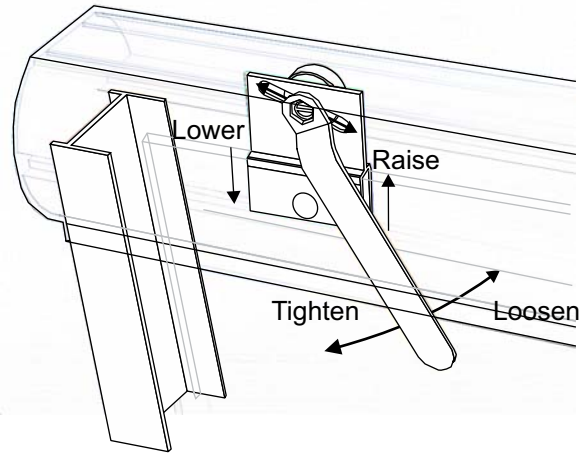

Header Attachment Detail

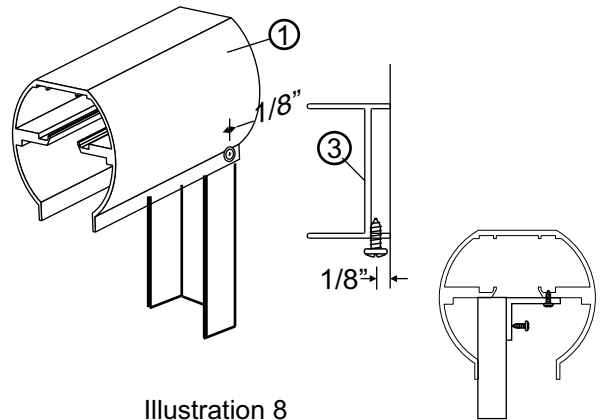

Sealant Detail

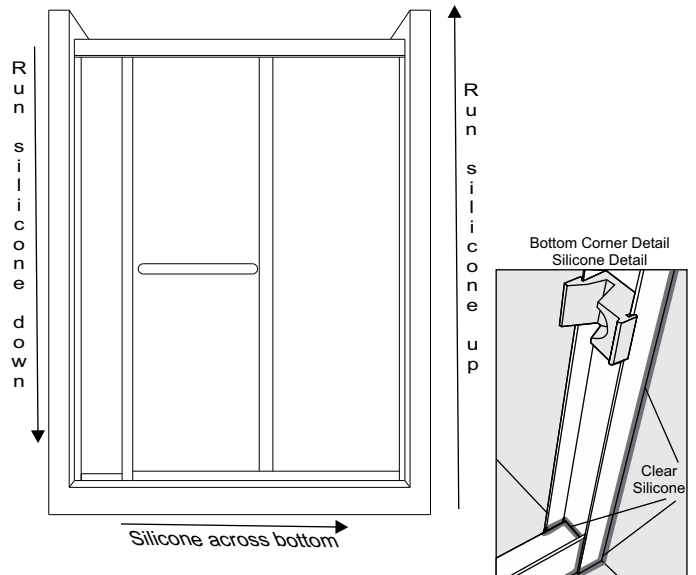

Towel Bar Installation

(Installation Instructions should also be inside the towel bar kits)

STEP 7 - DSE/DTE or SSE/STE w/ Standard Towel Bar (BP.27XX, xx = length)

- Refer to instructions provided with towel bar or use this general configuration below

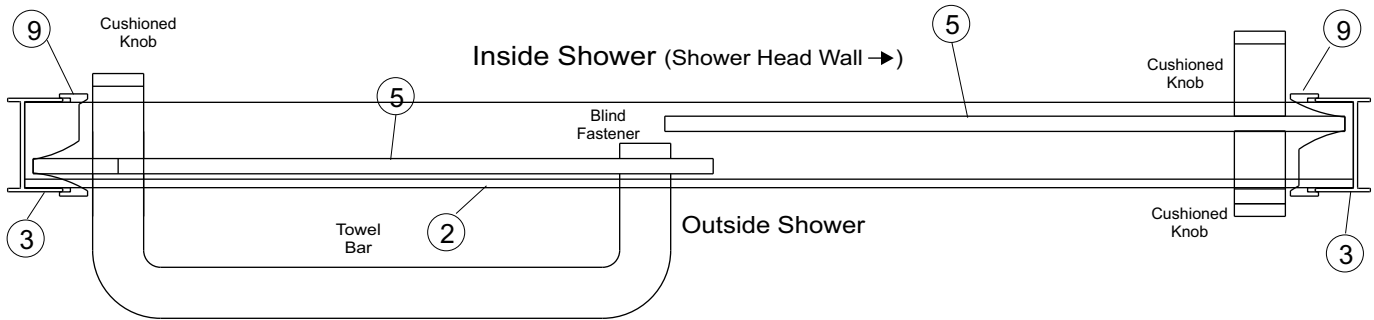

STEP 7 - DSE/DTE or SSE/STE w/ Optional Towel Bar (BP.3214)

- Refer to instructions provided with towel bar or use this general configuration below

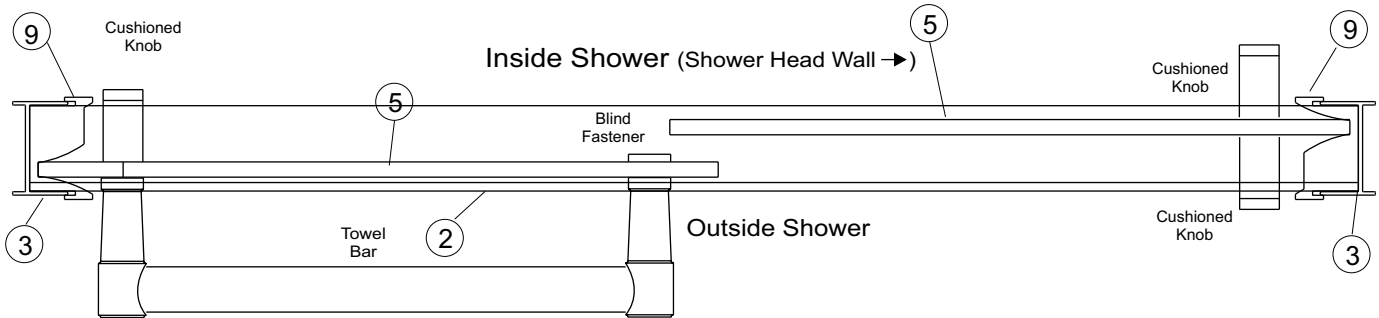

STEP 7 - CSE/CTE or VSE/VTE w/ Standard Double Towel Bar (BP.3344)

- Refer to instructions provided with towel bar or use this general configuration below
- NOTE: "U" shape vinyl is applied to edge of glass before attaching pull and brackets

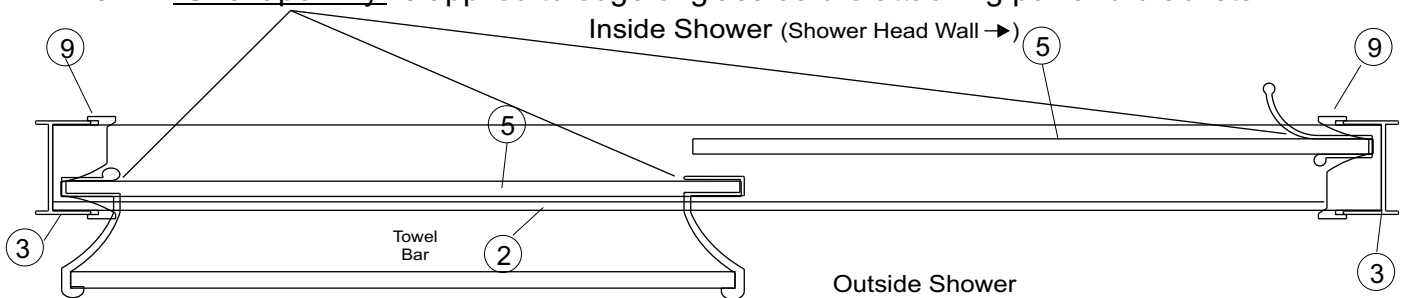

STEP 7 - BSD/BTE or FSE/FTE w/ Optional Towel Bar (BP.3214)

- Refer to instructions provided with towel bar or use this general configuration below

