

Installation Instructions for TRTE290/TRSE290 or ECTE290/ECSE290 3/8" Frameless Slider with 180° & 90° Panels

BP.5005.NTL - TR/EC 290 Add On Pack

FIRST STEPS - Identify the model number of your unit.



- Look on the white shipping label on the outer cardboard box.
- **Model number** on label should correspond to one listed above.

Pick a unit below that best represents your configuration.

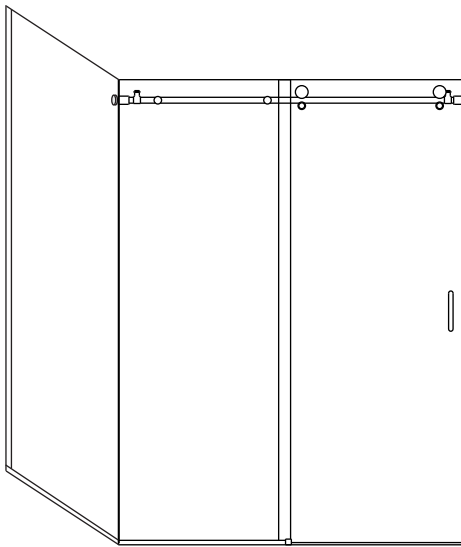

**TRSE290
ECSE290**

Shower Slider w/180° & 90° Panels

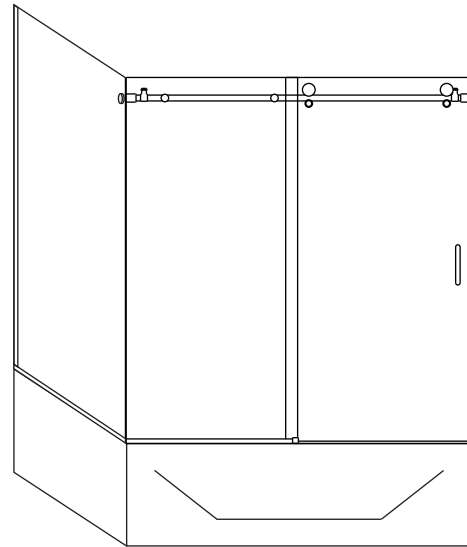

**TRTE290
ECTE290**

Tub Slider w/180° & 90° Panels

NOTE:

- Installation procedures are the same for tub or shower height units
- The images in this manual show an arrangement with the showerhead to the right. The same instructions apply for the opposite orientation where the examples would be reversed.

Required Tools

* Pencil or water soluble felt pen

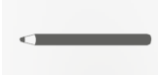

* Hacksaw with 24 tooth blade

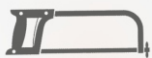

* Metal file (smooth sharp edges)



* Tape measure



* Clear 100% Silicone (recommended)



* #2 Phillips Screw driver



* 3/16", 1/4", 3/8" drill bits (carbide for tile)



* Caulking gun



* Drill, electric or battery



* 4 ft. Level



* Rubber mallet

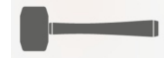

* Razor knife



P/N MM.5005
rev061920

READ ENTIRE MANUAL BEFORE INSTALLATION AND OPERATION

Warnings and General Shower Door Information



**SAFETY
WARNINGS:**



READ AND FOLLOW INSTRUCTIONS: Failure to follow all instructions, warnings and guidelines may result in serious injury or death, may cause water damage, and will void the terms of your warranty.

General Safety and Installation Policies

Before Installation:

- **Proper Size:** Ensure the enclosure is the proper size for your opening prior to beginning installation.
- **Safe Installation:** Some units may require two or more people to safely install the enclosure properly.
- **Packaging:** It is recommended to retain all packaging and other materials until installation is complete in the event of a return.
- **Inspect:** Installer should inventory all parts or components and inspect them for damage prior to beginning installation.
- **Sharp Edges:** Exposed ends of aluminum and other hard components can be rough, sharp or jagged due to the processes of cutting, drilling, notching, etc. Sharp ends must be deburred, smoothed or rounded by the installer before installation.
- **Safety equipment and tools:** Have all necessary safety equipment (glasses and gloves) and proper tools for the installation. The installer is responsible for determining the correct drill bit(s) for the installation.
- **New Tile:** We recommend that you allow at least 2 days (48 hours) for the tile cement and grout to dry before installing enclosure.

During Installation



- **Proper backing:** Shower doors are heavy. Therefore, glazing channels, fillers, hinges and headers blocks (structural components) should be secured to studs or solid backing beneath the tile or decorative substrate. Fasteners should screw directly into the backing. Wall anchors are provided primarily to separate screws from tile to reduce the possibility of cracking.

- **Tempered glass:** Glass can break. Shower door panels are tempered to ASTM C1048 specifications as required by building codes. Glass is tempered to greatly increase its strength and to make it fragment into smaller and lighter pieces reducing the possibility of injury in the event that the glass does break. Tempered glass will break and may cause bodily injury if you attempt to cut, drill, mill or alter it in any way. Care must be taken when handling tempered glass. Pay special attention to protect all edges of the glass from contact with hard surfaces.
- **Horizontal surfaces and installation holes:** Avoid drilling into the horizontal surfaces of tubs or showers unless it is required for the structural integrity of the unit. If you drill into horizontal surfaces, always generously caulk the holes, anchors, screws and on top of the screw head. If this is not done, or is done improperly, water damage can occur under the tile or substrate.
- **Weep holes in horizontal channels:** Drilling 3/8" weep holes on the inside of horizontal channels is recommended to allow any moisture build-up inside a channel to exit the channel. Due to varying installation conditions and installer's/owner's personal preference, however, we do not drill them in the factory.
- **Sliding and swinging glass doors:** A door may be improperly installed if it hits or scrapes against bathroom obstructions (toilets or cabinets) or any metal or glass components of the shower door itself. This could lead to glass breakage or serious injury. The installer must correct the deficiencies before allowing the door to be used.
- **Surface conditions:** Most shower door designs allow for out-of-square or unlevel installation. Generally, any outage more than 3/8" that was not identified during the ordering process is outside of these allowances and can result in an improper installation.

Caulking/Siliconing the Unit:

- Always clean all contact surfaces before caulking and use a high grade 100% silicone for best results.
- After installation, at a minimum, caulk the entire outside perimeter of the unit where the unit touches walls, sills, and step-ups, etc. Also caulk any vertical joints between metal components where water build-up inside of the channels could leak out.

After Installation:

- **Curing times:** Adhere to manufacturers' recommended curing times for VHB tapes, silicones and any other adhesives, coatings or chemicals used during installation. Unless otherwise stated, it is recommended to wait 72 hours before using the enclosure.
- **Normal wear and tear:** Although these enclosures are designed to last for years, certain items (such as the polycarbonate seals and door sweeps) may need to be replaced as they show signs of aging and wear.

General Disclaimers

- **Shower Doors are not watertight:** Consumers should understand that a shower door is not watertight. The amount of water that can escape your shower can vary greatly based on shower/tub size, configuration of shower head(s), type of thresholds and drains and by the type of shower door itself. Heavy glass units with no or limited vinyl seals, for example, can allow water to escape under normal conditions. Doors with more metal and seals generally provide more water protection. Excessive water pressure or directing shower heads or hand held sprays directly at doors or joints is not a normal shower conditions and can result in leaks.
- **Towel bars, handles and accessories** are in no way considered to be grab bars or other bracing or fall prevention mechanisms. The intent of these accessories is to facilitate proper operation or enhance the esthetics and functionality of the unit.

Owners Manual:

Refer to your Owners Manual for general installation and cleaning and care instructions. If a copy of the Owners Manual was not included, you can download one on the RESOURCES page of our website.

Questions or Comments:

1-800-843-3332

Installation Instructions

Models: TRTE290 / TRSE290 ECTE290 / ECSE290

3/8" Frameless Slider w/ 180° & 90° Panels

Figure 1 - Exploded View

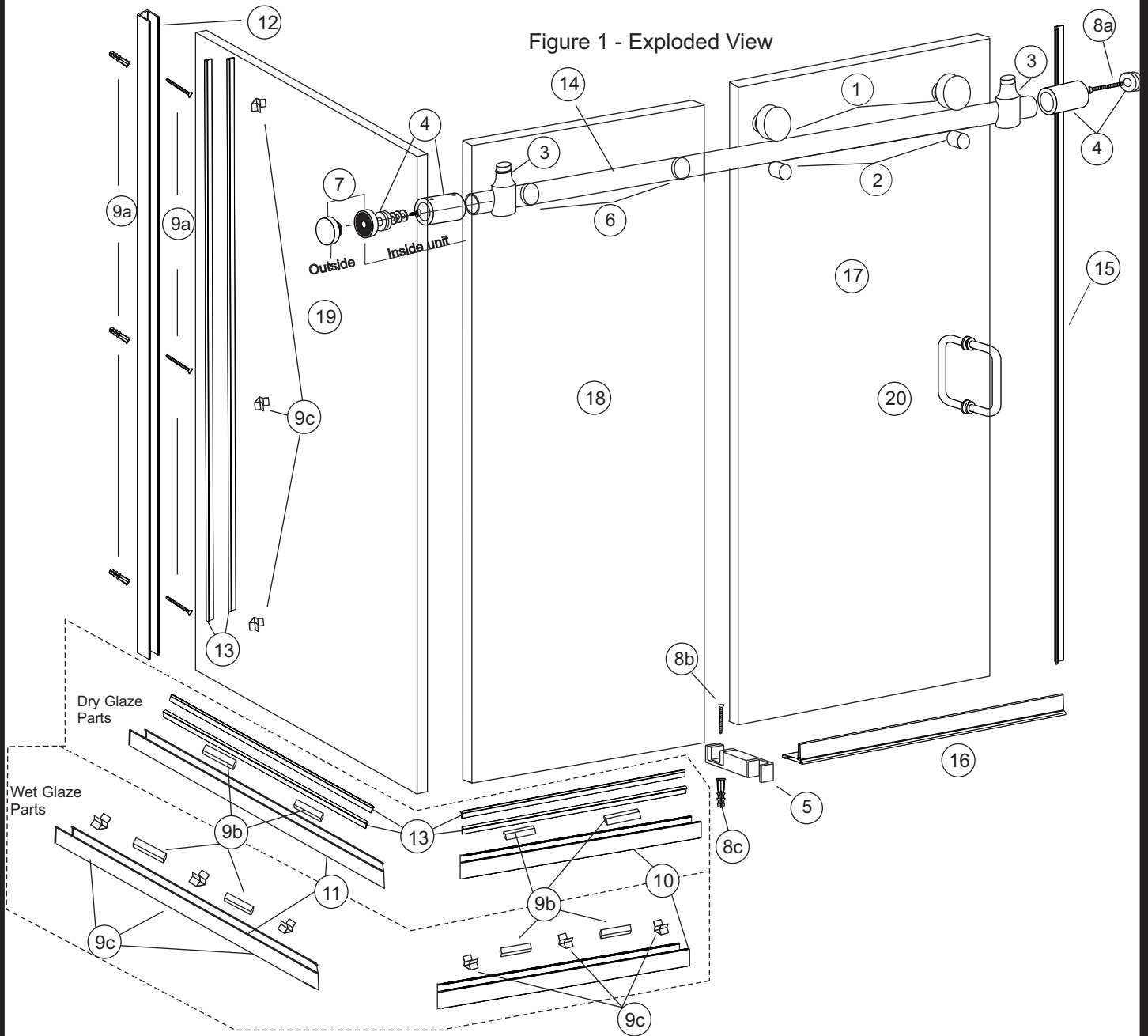

Parts List

HA.3101 HARDWARE PART BOX

- 1. HA.3001 - Roller Wheels ----- 2
- 2. HA.3002 - Anti Jump Knobs ----- 2
- 3. HA.3003 - Bumper Stops ----- 2
- 4. HA.3004 - Wall Collars / Pucks ---- 2
- 5. HA.3005 - Center Guide ----- 1
- 6. HA.3007 - Panel Fixers ----- 2
- 7. HA.3009 - 90° Connector ----- 1
- 8. BP.5001 - Parts Bag ----- 1
- 8a - M6 X 60mm Screw ----- 1
- 8b - M5 X 30mm Screw ----- 1
- 8c - M5 Wall Anchors ----- 1

BP.5005.SIL - Parts Bag

- 9a - BP.3027.SIL Part Bag ----- 1
- 9b - BP.3028.NTL Setting Blocks ----- 2
- 9c - SP.2221.CLR Centering Clips ----- 9
- 9d - MM.5005 Inst Sheet ----- 1

OTHER MAJOR COMPONENTS

- 10. EX.1018 - Panel Sill 180° ----- 1
- 11. EX.1018 - Panel Sill 90° ----- 1
- 12. EX.1018 - Wall Channel ----- 1
- 13. VN.4031 - Snap Vinyl ----- 6
- 14. HA.30XX - Header Tube ----- 1
- 15. VN.4083.CLR - Vertical Bulb seal --- 1
- 16. VN.4304 - Soft Sill Dam Strip ----- 1
- 17. Sliding Panel ----- 1
- 18. Fixed Panel ----- 1
- 19. 90° Return Panel ----- 1
- 20. HA.2701 - Handle ----- 1

Full Size Drawings:

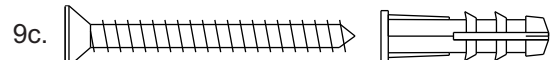
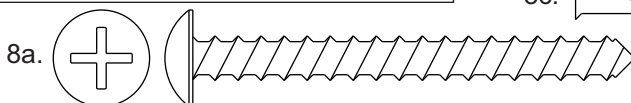
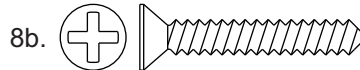

Extra screws may be provided for your convenience

Installation Instructions

Models: TRTE290 / TRSE290 ECTE290 / ECSE290

3/8" Frameless Slider w/ 180° & 90° Panels

STEP 1 - Mark the Centerline Dimensions You Supplied When You Ordered Unit:

- * Most parts are cut to size based on the dimension you supplied.
- * As accurately as possible, mark the ordering dimension on to the opening with a pencil or temporary marker. See Detail A
- * Make sure they are accurate.
- * This will line you up on the front and back wall to start the installation.

STEP 2 - Prepare Sill (11) and Wall Channel (12) for Installation (pick glazing method):

* Prepare Bottom Sill (11):

- The Bottom Channel (11), may already be cut to size.
- If not, measure the width of the Fixed Glass Panel (19) and add 1/2". This dimension includes the long point of the miter.
- Cut the square end of the Panel Sill, (11) to this length.
- Insert two 1/8" Clear Setting Blocks (9b).

- * **Choose either Dry or Wet** method of glazing the glass into the channels. Reference Page 3 for component detail:

- **DRY SEAL:** Will use two pieces of Snap Vinyl (13) after Glass Panel is in final position.

OR

- **WET SEAL:** In addition to the Setting Blocks, also insert three Centering Clips (9c) into the sill between setting blocks. You will have to silicone glaze both sides of the panel to the Bottom Channel after Panel is in final position.

STEP 3 - Install Channels for 90° Fixed Panel (19):

* Position the 90° Return Sill (11), detail B:

- Centered it on the pencil line and butted to the wall.
- Use blue painter's tape on both sides to securely to hold the sill in place.

* Check length of Wall Channel (12):

- Measure the height of the Glass Panel (19) and subtract 1/2".
- The length of Wall Channel (12) should be this length.

* Prepare the Wall Channel (12) on top of the sill (11) and against the wall.

- Use a level to plumb the channel and mark location on wall.
- Next mark hole locations for mounting screws inside the wall channel (usually at grout lines).
- Remove the Wall Channel and drill hole into the aluminum with 3/16" bit.

* Mount Wall Channel (12), detail C:

- Reposition the wall channel at marked location on the wall and mark hole locations on wall.
- Drill the holes with a 3/16" Drill bit, use carbide tip bit if going into masonry or tile.
- Insert 3/16 X 7/8 Wall Anchors (9a) into the holes.
- Fill the Anchors with silicone.
- Set the Wall Channel back in place and secure with #8 X 1-1/2 Screws (9a). See Detail C

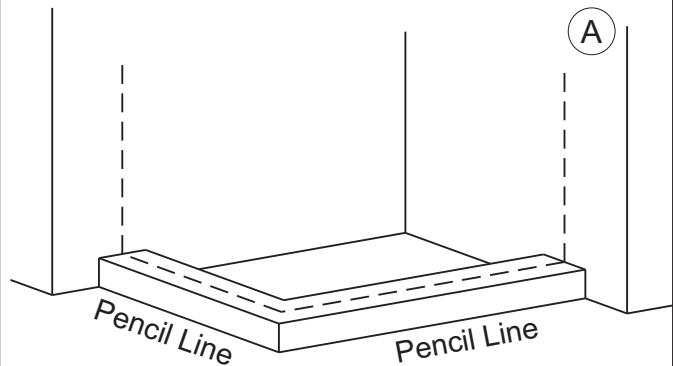

Choose Glazing Method

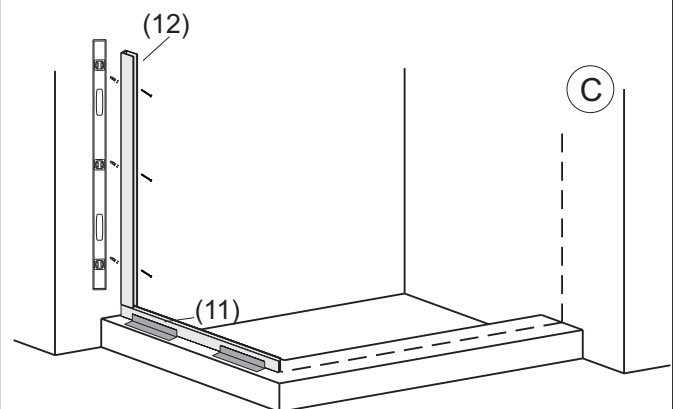
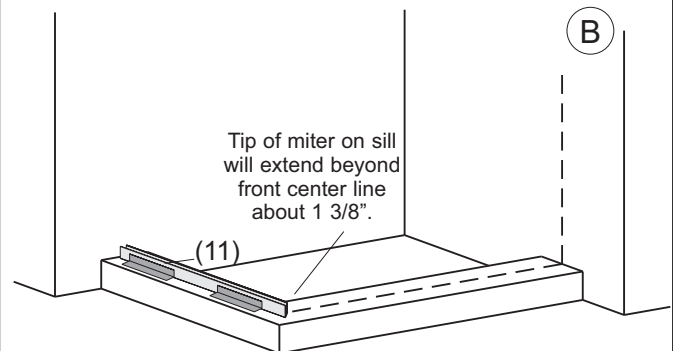
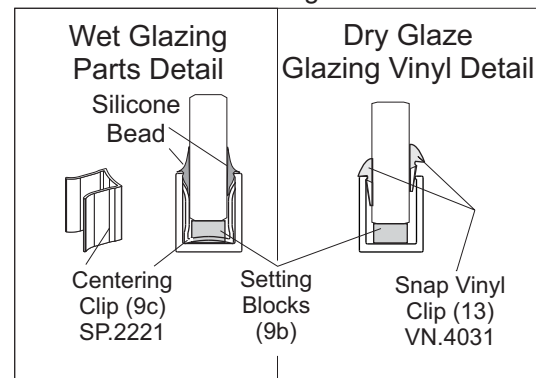

Installation Instructions

Models: TRTE290 / TRSE290 ECTE290 / ECSE290

3/8" Frameless Slider w/ 180° & 90° Panels

STEP 4 - Install the 90° Glass Panel (19), detail D:

- * Set the 90° Glass Panel (19) into the aluminum Sill (11) on the setting blocks and slide into the Wall Channel about 1/2".
- * The top of the Glass Panel (19) should be flush with the top of the Wall Channel.
- * Outside vertical edge of the panel must be plumbed leveled as shown with the arrow in Detail D.
- * Adjust as necessary using set blocks or other shims. Do not permanently glaze the panel at this point.

* NOTE: The Snap Vinyl can be used to temporarily secure the glass panel into position even if you have chosen Wet Seal method.

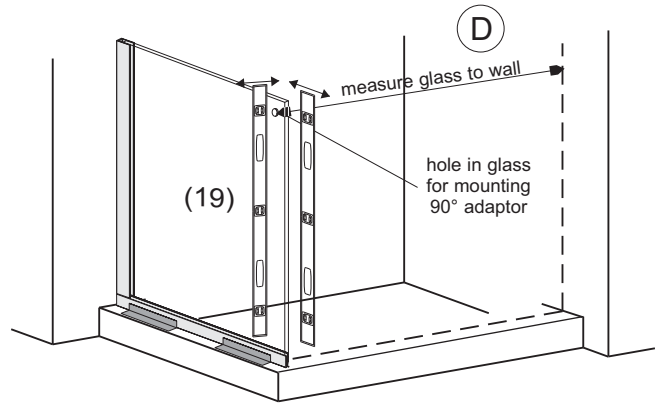

STEP 5 - Check Header Tube Length:

- * Note: Your Header Tube may already be cut to size.
 - To check, ensure the glass panel is plumb and measure the opening from glass below the 90° adaptor/collar to the opposite wall and subtract 2".
 - If your header is this dimension go to STEP 6.

- * If header is not cut to length See Detail DD.
 - Follow calculations to the right to determine the amount to cut from each end.
 - Follow instruction in Detail E below to cut the header (14) the proper length while keeping holes in proper location to match to glass.

DD

Check Header Length

$$\begin{aligned} &\text{Measured Header Length} \\ &\quad - (\text{Wall to Wall} - 2") \\ &= \text{"D"} \quad (\text{if "D"}=0, \text{header is proper length}) \end{aligned}$$

If the header's measured length is long:

$$\text{Take "D" (from above)} \div 2 = \text{"H"}$$

No Hole Side → Cut "H" - 1/4" Off

Two Hole Side → Cut "H" + 1/4" Off

NOTE: Two Hole dimension will be 1/2" longer than No Hole

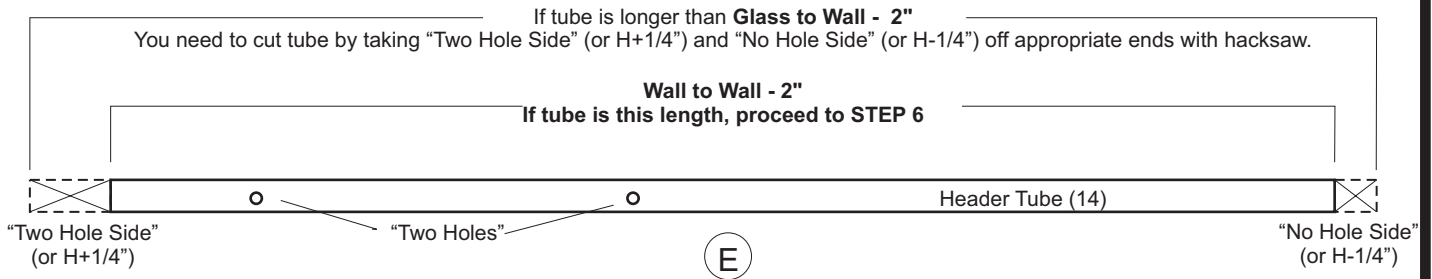

E

STEP 6 - Install Panel Connectors on Header Tube:

- * Orient Header Tube (14) so that the two holes are facing up.
- * Insert a screwdriver into the center hole of the tube.
- * Slide a Plug into tube stopping it with the screwdriver.
- * Manipulate the plug so that the hole in the plug lines up with the hole in the tube.
- * Put the screw through connector plate and into plug.
- * Snug screws with the supplied Allen wrench.
- * Repeat this procedure with the second hole closest to the end of the tube. See Detail F.

Panel Connector (6) (exploded)

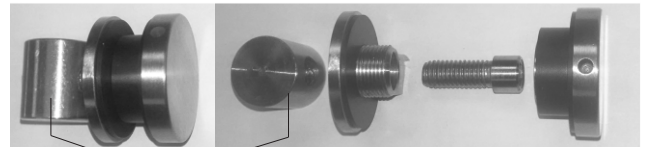

Plug goes inside header tube.
Align threaded plug holes with holes in header

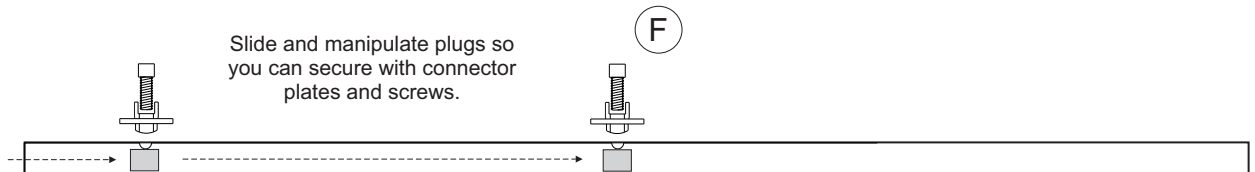

F

Installation Instructions

Models: TRTE290 / TRSE290 ECTE290 / ECSE290

3/8" Frameless Slider w/ 180° & 90° Panels

STEP 7 - Install Stoppers and Wall Collar on Header Tube:

- * Carefully slide stopper to initial locations about 3" onto the tube.
 - * Take care not to scratch the tube.
 - * Lightly tighten stopper set screw or secure with painter's tape so stoppers do not slide and scratch the tube.
 - * Final position will be determined during later steps.
 - * Opposite Side Wall Collar:
 - Slide other wall collar onto the opposite side of tube.
- See Detail FF.

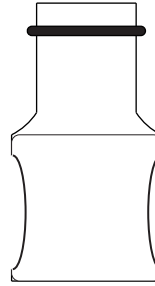

Stopper

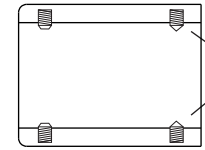

Wall Collar
(orient cone tipped set screws into puck)

(FF)

Carefully slide stopper to initial locations about 3" onto the tube.
Take care not to scratch the tube.
Lightly tighten stopper set screw so they do not inadvertently slide.

Slide collar onto tube and so end is slightly exposed

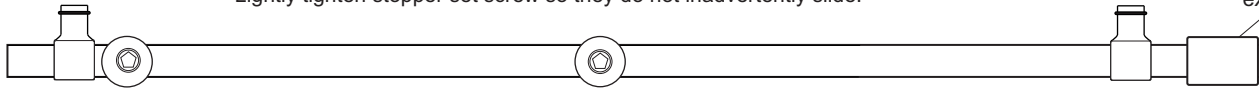

STEP 8 - Install 90° Panel Adaptor (7), see detail G:

- * Install the hardware as shown into the hole at top corner of the 90° Return panel, see Detail G.
- * Ensure Puck Slot is vertical. Use supplied washer to insure tight connection to the Glass.

(G)

90° Panel Adaptor Installation

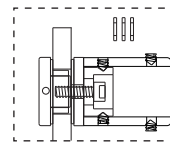

Elevation Side View

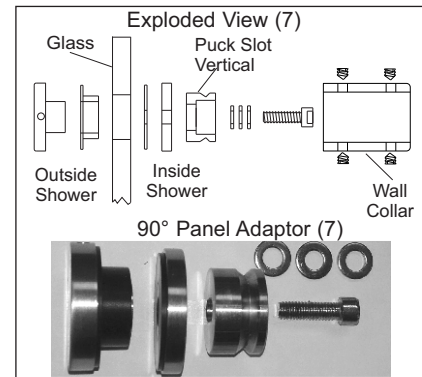

STEP 9 - Mount Second Puck on Opposite Wall:

- * THIS STEP REQUIRES ASSISTANCE
 - Carefully lift wall tube assembly and insert the open tube end into the puck already mounted on the 90° glass panel.
 - Take the second puck and hold it butted to the loose to end of the header tube and against wall on the centerline.
 - Level the tube with a level and mark the outline of the puck.
 - Remove tube assembly and mark puck slot on the centerline (keep slot vertical)
- * Drill your mark with a 3/16" bit.
- * Enlarge hole through tile with 5/16" carbide bit (to ensure screw will not crack tile).
- * Secure the Wall Puck (4) with one M6 X 50mm screw, (8a).

Orient the slot in Puck vertically when securing.

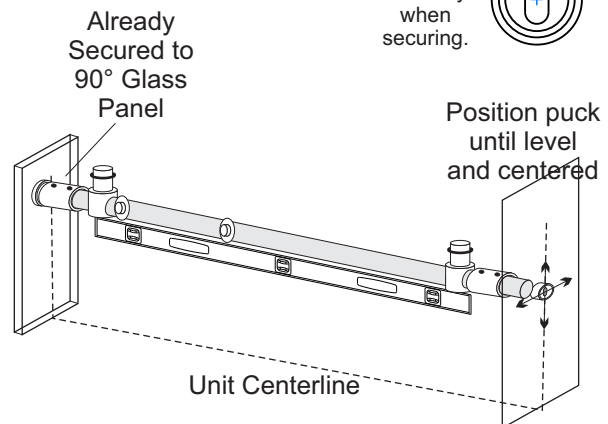
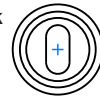

Installation Instructions

Models: TRTE290 / TRSE290 ECTE290 / ECSE290

3/8" Frameless Slider w/ 180° & 90° Panels

STEP 10 - Mount Header Tube:

- * Slide the Header Tube into wall collar on the Return Panel with stoppers pointed up.
- * Slide the loose Wall Collar off the Header Tube and onto the opposite Wall Puck taking care the tube does not fall.
- * Center the Header tube within both Wall Collars and align the Panel Fixers so they are facing to the outside.
- * Secure tube by tightening the set screws on each collar in the order shown (for best results).
- * **NOTE: Place Sliding Panel (17) inside the shower:**
 - Protect the glass edges from damaging or being damaged by the walls or shower base/pan.
 - Failure to put (17) inside will result in extra work that could result in damage to the sliding panel due to having to maneuver it through a smaller opening once the 180° panel (18) is placed.

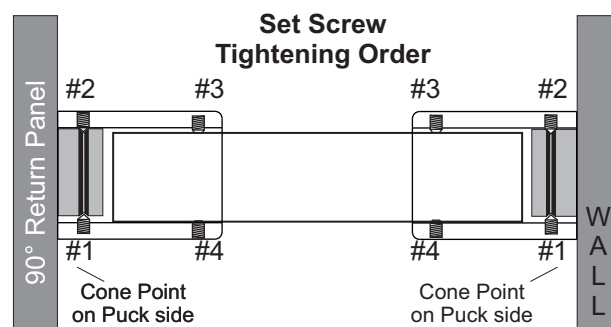
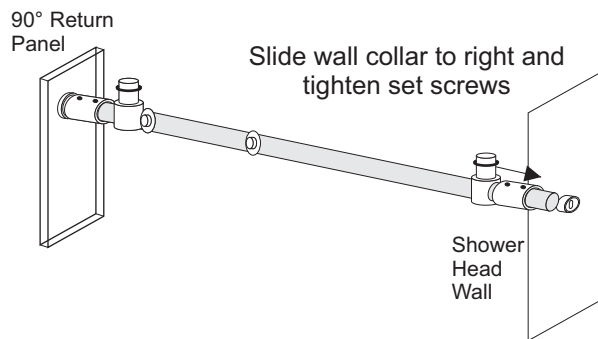

STEP 11 - Positioning Front Bottom Channel:

- * **Prepare Bottom Channel (10):**
 - The Bottom Channel (10), may already be cut to size.
 - To check, measure the width of the 180° Fixed Glass Panel (18) then subtract 1/4".
 - If needed, cut sill to this dimension measuring from the long point of the miter.
 - Insert two 1/8" Clear Setting Blocks (9b) and add 3 - Centering Clips (9c) if you used them in the adjoining panel sill.
- * **Position Bottom Channel:**
 - Apply silicone on the three faces of the mitered channel already in place to seal the corner.
 - approximately 1" in front of the marked Centerline (measured to center of channel).
 - Securely tape into position with blue painter's tape on the inside and outside to ensure it channel does not slip when you put the panel in.

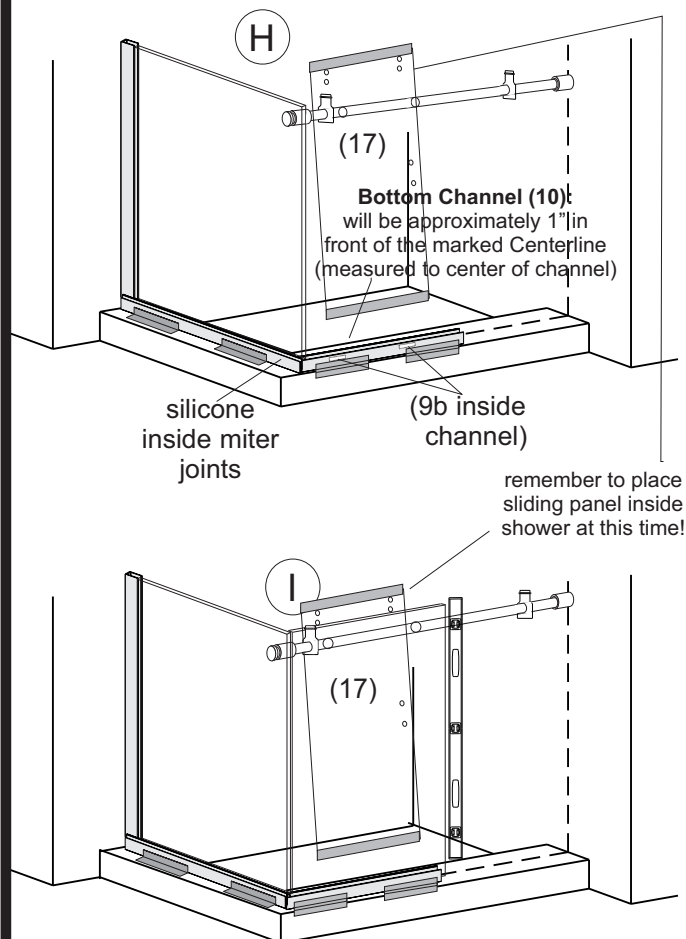

Installation Instructions

Models: TRTE290 / TRSE290 ECTE290 / ECSE290

3/8" Frameless Slider w/ 180° & 90° Panels

STEP 12 - Mounting the Front Fixed Glass Panel:

- * Set the 180° Glass Panel (18) into the Panel Sill (10):
 - Spaced panel 1/8" off of the Return Panel.
 - **NOTE:** 1/8" gap will be filled with silicone during final steps of installation.
- The Glass Panel will protrude out of the end of the channel.
- * Holes in the glass should line up with the two Panel Connectors on the Header Tube.
- * **NOTE:** If they don't, you may have to raise or lower the panel (18) by adjusting the Setting Blocks
- * And / Or, adjust puck slot on the wall to raise or lower Tube to adjust up and down and possibly rotate the Header Tube to square it up to the panel.
- * After the panel is adjusted, secure the Panel to the Header Tube with Panel Connector Cap. Tighten securely using Allen wrenches supplied.
- * With the top of the Panel secured:
 - Loosen blue tape
 - Use a rubber mallet and tap the Panel Sill and the panel at the bottom to the plumb position using a level.
- * Securely tape bottom channel to floor with painter's tape.

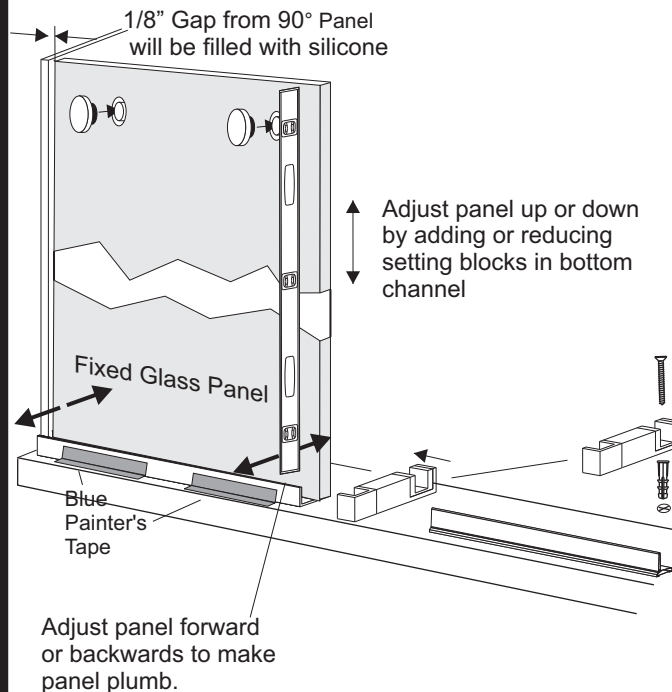

STEP 13 - Center Guide:

- * Set the Center Guide (5) in place on the threshold and over the edge of the Fixed Panel.
- * **NOTE:** The Center Guide is reversible by loosening the set screw and rotating the receiver.
 - Open "U" without black insert cups over the exposed edge of panel.
 - Black insert side should point up and be positioned to the inside of unit as shown.
- * Mark the hole location and drill with a 1/4" Drill bit. Insert Wall Anchor (8c).
- * Fill Wall Anchor and hole with silicone and put a bead on the bottom of the Guide.
- * Secure guide with one #10 X 1-1/8 FHPH Screw (8b).

STEP 14 - Mounting the Sliding Panels:

- * Take the Inside Sliding Panel (17), mount 2 Wheel assemblies (1) as shown.
- * **NOTE:** The Wheel will face to the outside of the shower.
- * By rotating plate between roller and glass, adjust the roller so you have equal up and down adjustment.
- * **NOTE:** Once roller is adjusted to desired height, ensure inner plate is not rotated.
- * Tighten the roller securely as shown by rotating back cap.
- * Repeat for second roller (1). Tighten the rollers securely using the two 3mm Allen Wrenches.

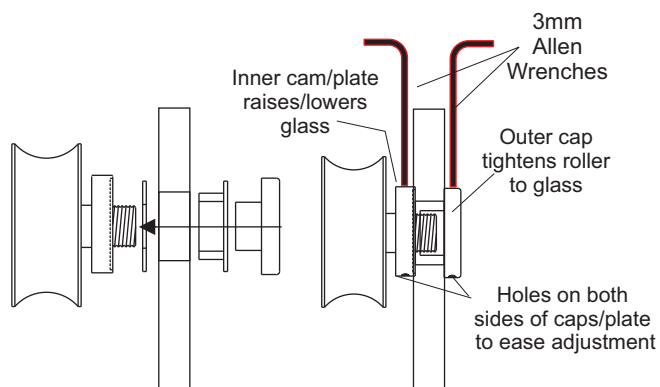

Placement and Measuring Guide for TRSE290 or ECSE290 Bypass Sider

This flyer should be integrated with the TRSE290 and ECSE290 Installation Instruction MM.5005

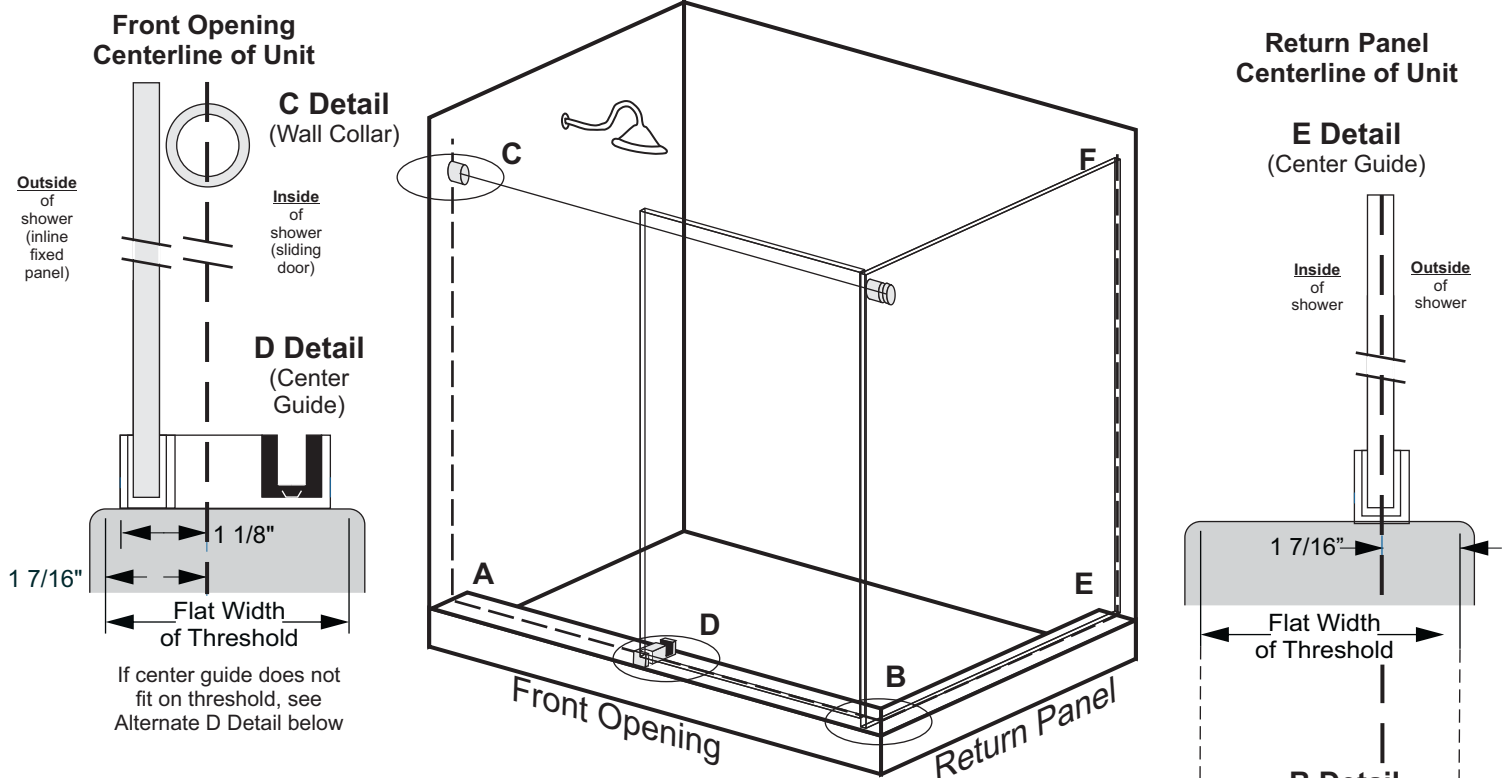

Front Opening Centerline (A to B)

- The "flat width" of the threshold does not include rounded edges
- Measure 1 7/16" from the front start of the flat to locate the Front Opening Centerline of the unit. Draw this line from A to B.

Vertical Centerline (A to C)

- Using a level, extend the Front Opening Centerline vertically up the wall
- Note the Wall Collar is installed on this centerline (Detail D)

Center Guide (Detail D)

- The center guide will extend approximately 1 1/8" in front of the Front Opening Centerline (A to B). This can deviate somewhat due to adjustments made during installation.
- **Alternate D Detail:** If the "flat" is less than approximately 3 1/4", the center guide may hang over the back. This is common for many molded shower pans. It can prohibit you from using a screw and anchor to secure the center guide. Use high quality VHB tape and silicone to secure the center guide as shown to the right. High strength 5 minute epoxy can be used to secure the black door silencer/guide into the base.

Return Panel Centerline (B to E)

- Measure 1 7/16" from the front start of the flat to locate the Return Panel (RP) Centerline of the unit
- Extend line B to E the length of the Return Panel

Vertical Centerline (E to F)

- Using a level, extend the RP Centerline vertically up the wall
- Note the Wall Channel used to glaze glass panel will be centered on the centerline

How to Measure:

- To provide proper Front Opening dimension, measure from A to B. Use a level to check conditions. There should be no more than 1/4" deviation from A to B
- Return Panel dimension is B to E. There should be no more than 1/4" deviation from B to E
- Measure the desired or standard height of your unit along A to C and E to F

Alternate D Detail (Center Guide)

Overhanging Center Guide

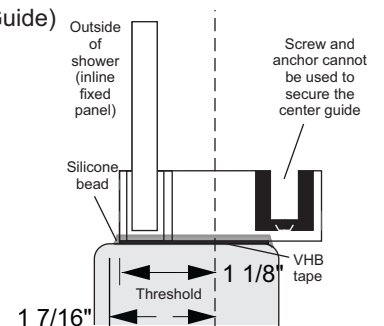

Installation Instructions

Models: TRTE180 / TRSE180 ECTE180 / ECSE180

3/8" Frameless Slider & 180° Panel

STEP 15 - Hanging and Adjusting the Sliding Panel:

- * From inside of the shower, carefully lift Sliding Panel (17) onto the Header Tube (14) and into the Center Guide (5).
- * Move each Bumper Stop (3) towards the walls.
- * **Shower Head Wall:** bring the Sliding Panel to the closed position, leaving an even 1/4" gap at the shower head wall.
- * NOTE: you may have to individually adjust the rollers up or down if wall and the edge of panel does not have equal reveal from top to bottom.
- * Secure bumper stop by tightening set screw located at the top of the bumper stop. Tighten this well!
- * **Stationary Panel Wall:** slide the sliding panel (17) to the open position behind stationary panel (18).
- * Slide the bumper stop to stop the roller:
 - at least 1" from center of handle holes
 - OR
 - so the back edge of sliding panel is 5/8" or more from the 90° Return Panel.
 - WHICHEVER HAPPENS FIRST
- * Tighten second bumper stop well!

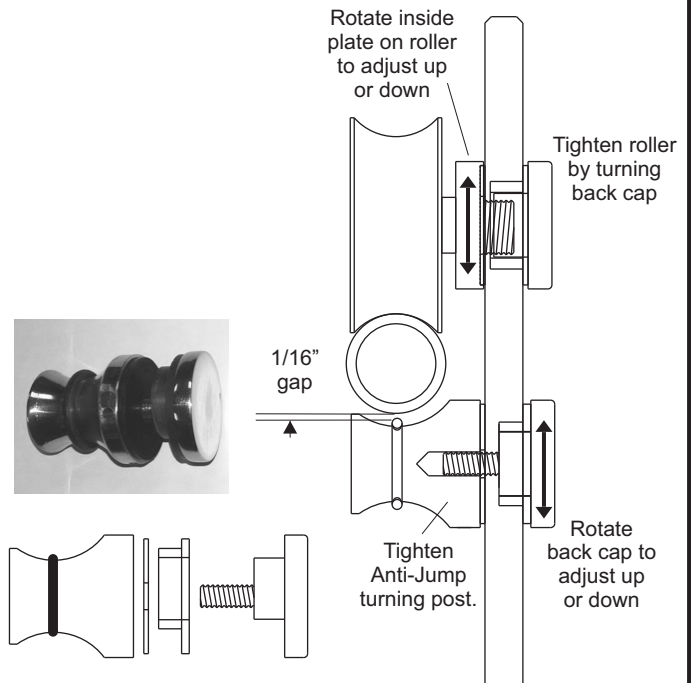

STEP 16 - Anti Jump Posts (2):

- * Install Anti Jump Posts as shown.
- * Adjust posts until they come within 1/16" of the bottom of the bar.
- * NOTE: Test to make sure the anti-jumps restrict the rollers from coming off the tube.
- * Tighten Anti-Jump post securely, holding the back cap in adjusted location.

STEP 17 - Install Handle (20):

- * Install handle with instructions provided.
- * Ensure handle does not hit stationary glass panel.

STEP 18 - Install Bumper Seal (15):

- * Measure sliding panel top to bottom, deduct 1/8"
- * Cut bumper seal (15) to this length and tap it onto edge of sliding panel (17) on shower head side.



STEP 19 - Soft Sill (16):

- * Measure from center guide to wall and deduct 1/16"
- * Clean adhesion area under Soft Sill with alcohol and dry.
- * Cut Soft Sill to dimension. Peel the backing off the tape on the sill and stick in place.

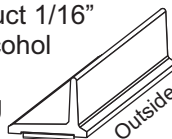

STEP 20 - Final Glazing/Silicone: GE1200 Recommended

- * Run a bead of Silicone vertically to seal the Front panel (18) to the Return Panel (19). Blue Painters tape is recommended to assist in this step.
- * Install Snap Vinyl (13) or run a bead of Silicone along the horizontal edge of the of bottom channel where it meets the glass panel, and along the entire inside and outside of threshold.
- * Silicone gaps between center guide and glass.
- * NOTE: Let silicone dry and tape cure for 24 hours before use.

