

Installation Instructions for HSD290/ESD290/QSD290 or HLSD290/ELSD290/QLSD290

Swing Door with 180° Notched Panel w/ Return

FIRST STEPS - Identify the model number of your unit.

- Look on the white shipping label on the outer cardboard box.
- **Model number** on label should correspond to one listed above.

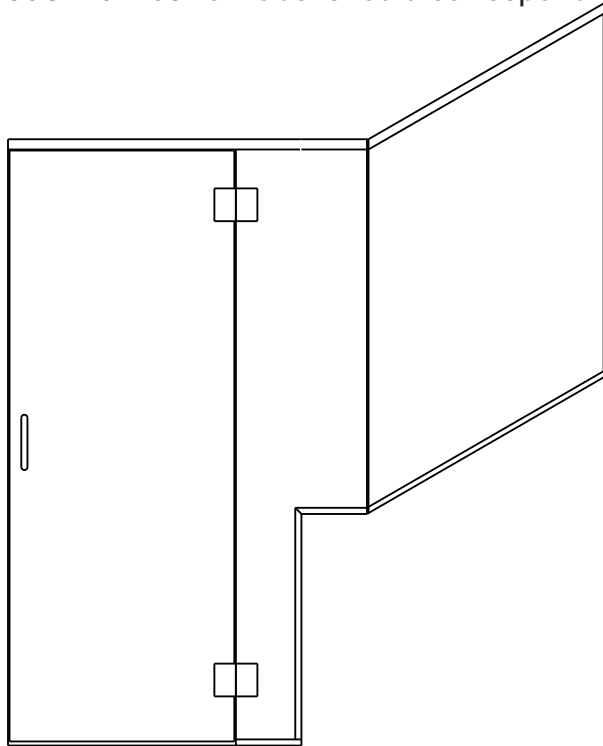

HSD290/ESD290/QSD290 HLSD290/ELSD290/QLSD290

NOTE:

- Installation procedures are the same for tub or shower height units
- The images in this manual show an arrangement with the showerhead to the left. The same instructions apply for the opposite orientation where the examples would be reversed.

Required Tools

* Pencil or water soluble felt pen

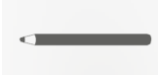

* Hacksaw with 24 tooth blade

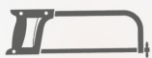

* Metal file (smooth sharp edges)



* Tape measure



* Clear 100% Silicone (recommended)



* #2 Phillips Screw driver



* 3/16", 1/4", 3/8" drill bits (carbide for tile)



* Caulking gun



* Drill, electric or battery



* 4 ft. Level



* Rubber mallet



* Razor knife



P/N MM.5015C
rev061920

READ ENTIRE MANUAL BEFORE INSTALLATION AND OPERATION

Warnings and General Shower Door Information



**SAFETY
WARNINGS:**



READ AND FOLLOW INSTRUCTIONS: Failure to follow all instructions, warnings and guidelines may result in serious injury or death, may cause water damage, and will void the terms of your warranty.

General Safety and Installation Policies

Before Installation:

- **Proper Size:** Ensure the enclosure is the proper size for your opening prior to beginning installation.
- **Safe Installation:** Some units may require two or more people to safely install the enclosure properly.
- **Packaging:** It is recommended to retain all packaging and other materials until installation is complete in the event of a return.
- **Inspect:** Installer should inventory all parts or components and inspect them for damage prior to beginning installation.
- **Sharp Edges:** Exposed ends of aluminum and other hard components can be rough, sharp or jagged due to the processes of cutting, drilling, notching, etc. Sharp ends must be deburred, smoothed or rounded by the installer before installation.
- **Safety equipment and tools:** Have all necessary safety equipment (glasses and gloves) and proper tools for the installation. The installer is responsible for determining the correct drill bit(s) for the installation.
- **New Tile:** We recommend that you allow at least 2 days (48 hours) for the tile cement and grout to dry before installing enclosure.

During Installation



- **Proper backing:** Shower doors are heavy. Therefore, glazing channels, fillers, hinges and headers blocks (structural components) should be secured to studs or solid backing beneath the tile or decorative substrate. Fasteners should screw directly into the backing. Wall anchors are provided primarily to separate screws from tile to reduce the possibility of cracking.

- **Tempered glass:** Glass can break. Shower door panels are tempered to ASTM C1048 specifications as required by building codes. Glass is tempered to greatly increase its strength and to make it fragment into smaller and lighter pieces reducing the possibility of injury in the event that the glass does break. Tempered glass will break and may cause bodily injury if you attempt to cut, drill, mill or alter it in any way. Care must be taken when handling tempered glass. Pay special attention to protect all edges of the glass from contact with hard surfaces.
- **Horizontal surfaces and installation holes:** Avoid drilling into the horizontal surfaces of tubs or showers unless it is required for the structural integrity of the unit. If you drill into horizontal surfaces, always generously caulk the holes, anchors, screws and on top of the screw head. If this is not done, or is done improperly, water damage can occur under the tile or substrate.
- **Weep holes in horizontal channels:** Drilling 3/8" weep holes on the inside of horizontal channels is recommended to allow any moisture build-up inside a channel to exit the channel. Due to varying installation conditions and installer's/owner's personal preference, however, we do not drill them in the factory.
- **Sliding and swinging glass doors:** A door may be improperly installed if it hits or scrapes against bathroom obstructions (toilets or cabinets) or any metal or glass components of the shower door itself. This could lead to glass breakage or serious injury. The installer must correct the deficiencies before allowing the door to be used.
- **Surface conditions:** Most shower door designs allow for out-of-square or unlevel installation. Generally, any outage more than 3/8" that was not identified during the ordering process is outside of these allowances and can result in an improper installation.

Caulking/Siliconing the Unit:

- Always clean all contact surfaces before caulking and use a high grade 100% silicone for best results.
- After installation, at a minimum, caulk the entire outside perimeter of the unit where the unit touches walls, sills, and step-ups, etc. Also caulk any vertical joints between metal components where water build-up inside of the channels could leak out.

After Installation:

- **Curing times:** Adhere to manufacturers' recommended curing times for VHB tapes, silicones and any other adhesives, coatings or chemicals used during installation. Unless otherwise stated, it is recommended to wait 72 hours before using the enclosure.
- **Normal wear and tear:** Although these enclosures are designed to last for years, certain items (such as the polycarbonate seals and door sweeps) may need to be replaced as they show signs of aging and wear.

General Disclaimers

- **Shower Doors are not watertight:** Consumers should understand that a shower door is not watertight. The amount of water that can escape your shower can vary greatly based on shower/tub size, configuration of shower head(s), type of thresholds and drains and by the type of shower door itself. Heavy glass units with no or limited vinyl seals, for example, can allow water to escape under normal conditions. Doors with more metal and seals generally provide more water protection. Excessive water pressure or directing shower heads or hand held sprays directly at doors or joints is not a normal shower conditions and can result in leaks.
- **Towel bars, handles and accessories** are in no way considered to be grab bars or other bracing or fall prevention mechanisms. The intent of these accessories is to facilitate proper operation or enhance the esthetics and functionality of the unit.

Owners Manual:

Refer to your Owners Manual for general installation and cleaning and care instructions. If a copy of the Owners Manual was not included, you can download one on the RESOURCES page of our website.

Questions or Comments:

1-800-843-3332

Installation Instruction

Models: HSD290 (1/2-in), ESD290 (3/8-in) or QSD290 (1/4-in)
Models: HLSD290 (1/2-in), ELSD290 (3/8-in) or QLSD290 (1/4-in)
 WITH HEADER, NOTCHED PANEL AND STEP RETURN

* PLEASE NOTE: Before beginning the installation, read the instructions and check that the parts contained in the carton and hardware package match those parts listed below. If you should find any discrepancies please contact HOLCAM SALES at 800-843-3332

WARNING: To avoid damage to the finish of this deluxe enclosure, use only mild cleaners. Always read the label on the cleaner to be used. Do not use harsh chemicals or abrasive cleaners.

HINGE ASSEMBLY

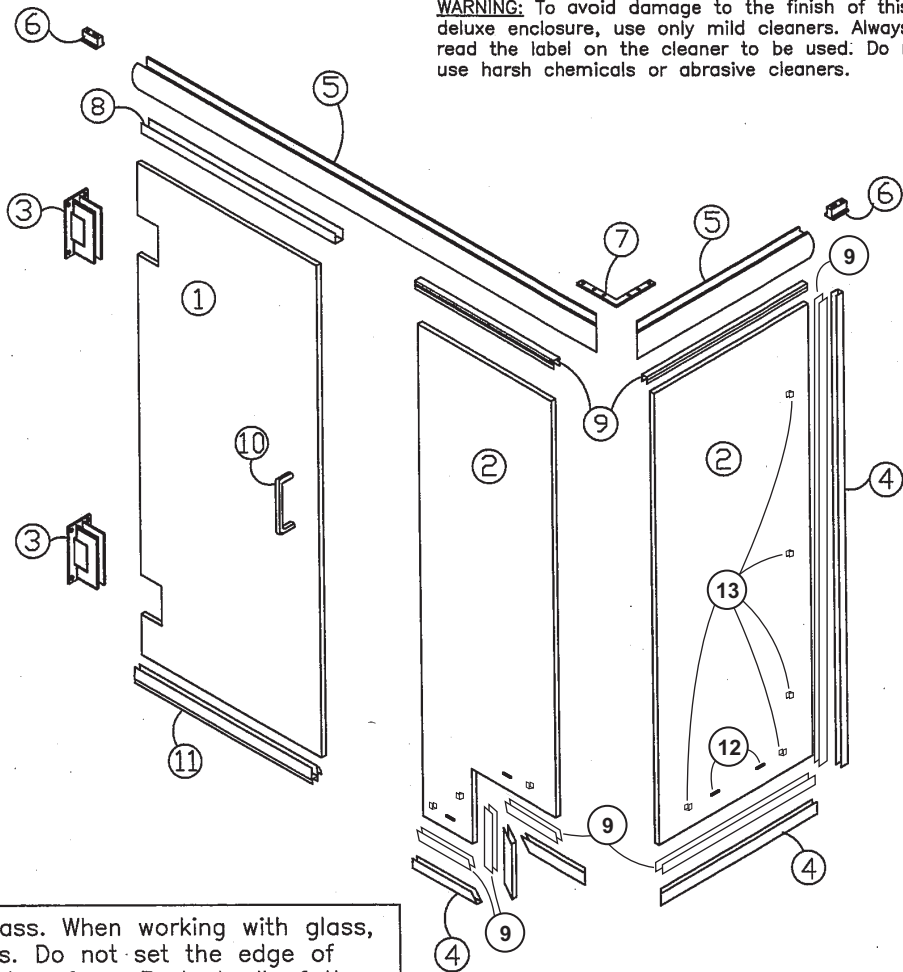
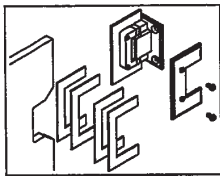

WARNING: This is tempered glass. When working with glass, protect the edges at all times. Do not set the edge of the glass directly on any hard surface. Protect all of the edges from impact with with hard surface or object.

PARTS LIST

1. Glass door
2. Glass panel
3. Eurolite Wall Hinge Assembly
4. Glazing Channel
5. Header
6. Header Bracket
7. Corner Bracket
8. Crown Filler
9. Snap Glazing Vinyl (dry glaze)
10. Handle
11. Vinyl Sweep
12. Setting Blocks
13. Centering Clips (wet/silicone glaze)

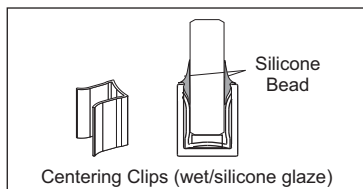

ASSEMBLY HARDWARE

ITEM NAME QTY.



1. 10 x 2" Screws



2. 8 x 1-1/2" Screws

3. Plastic Anchor



Setting Blocks



Glazing Channel

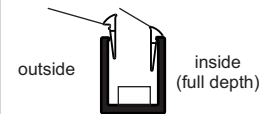

Snap Glazing Vinyl (dry glaze)

Installation Instruction

Models: HSD290 (1/2-in), ESD290 (3/8-in) or QSD290 (1/4-in)

Models: HLSD290 (1/2-in), ELSD290 (3/8-in) or QLSD290 (1/4-in)

WITH HEADER, NOTCHED PANEL AND STEP RETURN

1. MARK THE CENTERLINE OF SILL LIGHTLY IN PENCIL.

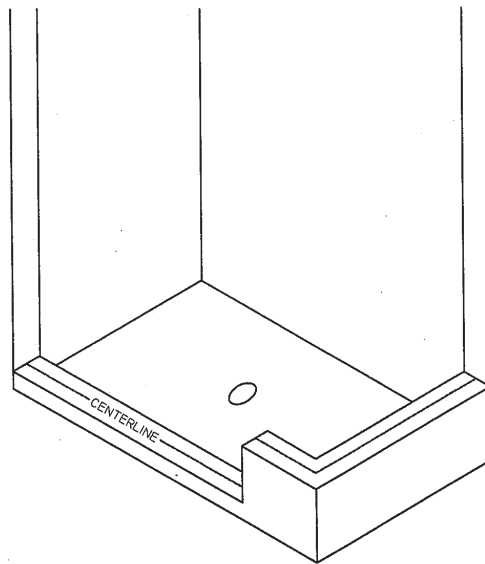

2. CENTER THE BOTTOM CHANNEL ON PENCIL MARK ON THE SILL WITH THE CHANNEL BUTTED UP AGAINST THE WALL. MARK THE MOUNTING HOLES, REMOVE CHANNEL AND DRILL $3/16$ " HOLES. INSERT THE PLASTIC ANCHORS, AND PLACE A DAB OF SILICONE IN THE ANCHOR. SECURE THE CHANNEL TO THE STEP WALL WITH #8X1-1/2" SCREWS. POSITION THE WALL CHANNEL CENTERED ABOVE THE BOTTOM U-CHANNEL. PLUMB THE CHANNEL AND MARK THE MOUNTING HOLE LOCATIONS. DRILL $3/16$ " HOLES AND INSERT PLASTIC ANCHORS. SECURE CHANNEL TO WALL WITH #8X1-1/2" SCREWS.

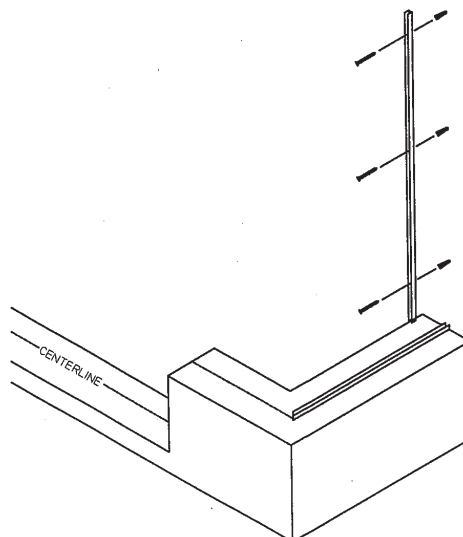

Installation Instruction

Models: HSD290 (1/2-in), ESD290 (3/8-in) or QSD290 (1/4-in)

Models: HLSD290 (1/2-in), ELSD290 (3/8-in) or QLSD290 (1/4-in)

WITH HEADER, NOTCHED PANEL AND STEP RETURN

3A. MEASURE FROM THE OUTSIDE OF THE MITERED RETURN CHANNEL TO THE OUTSIDE OF A CHANNEL VERTICAL AGAINST THE STEP ON THE CENTERLINE. CUT THE CHANNEL OVERSIZED AND TRIM TO FIT. INSTALL IN THE SAME MANNER AS THE PREVIOUS BOTTOM CHANNEL. MEASURE FROM THE TOP OF THE POINT OF THE CHANNEL ON THE TOP OF THE STEP DOWN TO THE TOP OF THE SILL. MEASURE AND MARK THE CHANNEL FOR THE VERTICAL FACE OF THE STEP. CUT 45° MITER AND TEST FIT THE PART. SEAL EXPOSED SCREW HEADS WITH SILICONE.

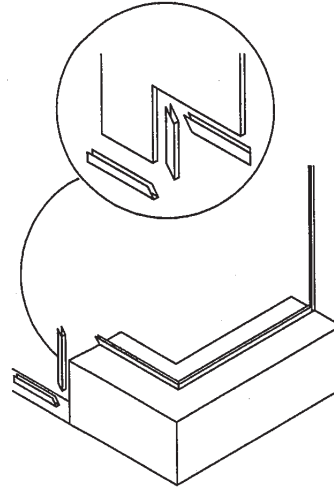
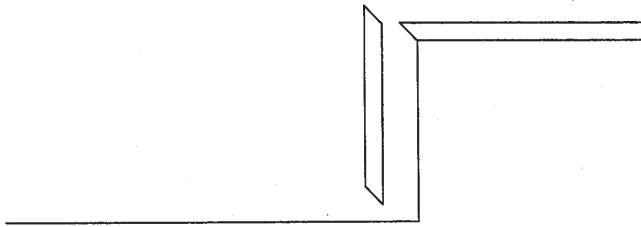

3B. MEASURE THE WIDTH OF THE LEG OF THE NOTCHED GLASS PANEL. MEASURE AND MARK THE BOTTOM CHANNEL. CUT THE BOTTOM CHANNEL TO SIZE AT THE SQUARE END. TEST FIT THE VERTICAL AND HORIZONTAL CHANNELS FOR A PROPER FIT. TRIM AS NEEDED.

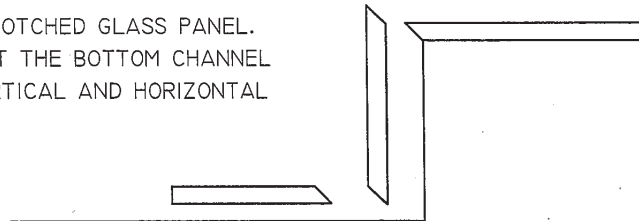

3C. DRILL THE HOLES FOR MOUNTING THE CHANNELS THROUGH THE BOTTOM WALL OF THE CHANNELS. POSITION CHANNELS ON SILL AND MARK THE MOUNTING HOLE LOCATIONS. DRILL HOLES AND APPLY SOME SILICONE TO THE MOUNTING HOLES. SECURE CHANNELS TO SILL WITH #8 X1-1/2" SCREWS. SEAL ALL EXPOSED SCREW HEADS WITH SILICONE.

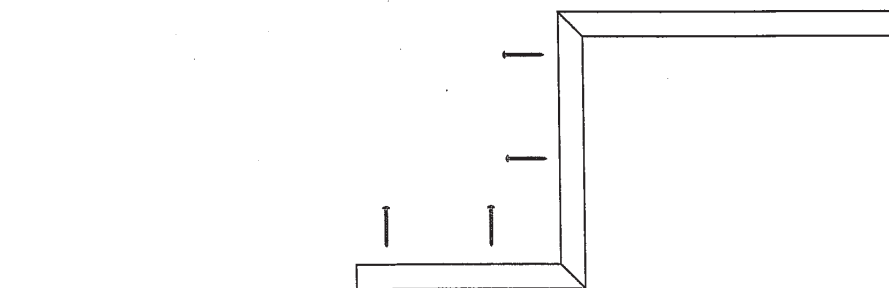

Installation Instruction

Models: HSD290 (1/2-in), ESD290 (3/8-in) or QSD290 (1/4-in)

Models: HLSD290 (1/2-in), ELSD290 (3/8-in) or QLSD290 (1/4-in)

WITH HEADER, NOTCHED PANEL AND STEP RETURN

4. PLACE 1/2" SHIMS ALONG THE SILL TO SET THE DOOR GLASS ON. SET THE DOOR ON THE SHIMS WITH THE HINGE BACKING PLATES AGAINST THE WALL. ADJUST THE SHIMS TO PROVIDE 3/8" SPACING BETWEEN THE BOTTOM EDGE OF THE DOOR GLASS AND THE HIGHEST POINT ON THE SILL. ALIGN DOOR WITH THE PANEL GLASS. MARK MOUNTING HOLE LOCATIONS. MAKE SURE THAT THE HINGE PLATES WILL BE PLUMB, OUT OF PLUMB HINGES WILL CAUSE THE GLASS TO MOVE IN THE HINGES. REMOVE DOOR AND SET ASIDE ON A PADDED SURFACE SUCH AS CARDBOARD, CARPET ETC. DRILL 1/4" HOLES IN THE FINISH WALL MATERIAL ONLY. THEN USE A 9/64" BIT CENTERED IN THE 1/4" HOLE TO DRILL PILOT HOLES INTO THE STUD.

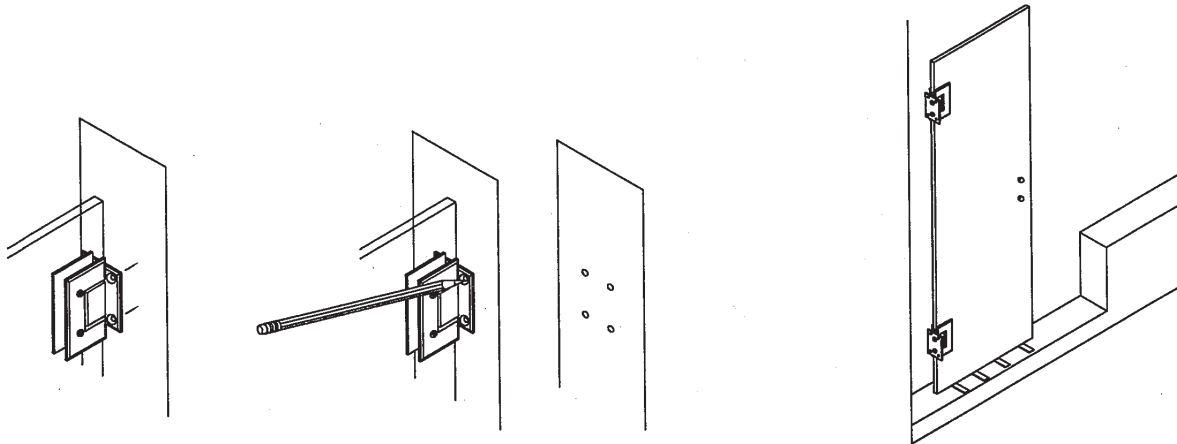

NOTE: COVERING THE FACE OF THE HINGES WITH PAINTERS TAPE WILL HELP PREVENT SCRATCHES.

5. REMOVE THE HINGES FROM THE DOOR GLASS. MOUNT HINGES TO WALL WITH #10x2" SCREWS. INSTALL THE HINGES SO THAT THE CLAMPING SCREWS ARE ON THE INSIDE OF THE SHOWER. INSTALL THE RUBBER GASKETS ON EACH HINGE. POSITION NOTCH IN GLASS INTO HINGE. INSTALL REMAINING RUBBER GASKETS AND THE BACKING PLATE OF THE HINGE WITH THE HEX HEAD SET SCREWS. ADJUST GLASS PANELS TO HAVE 3/16" SPACING BETWEEN THEM. PLUMB GLASS AND TIGHTEN THE SET SCREWS IN THE SEQUENCE SHOWN. REMOVE SHIMS AND CHECK DOOR FOR PROPER OPERATION.

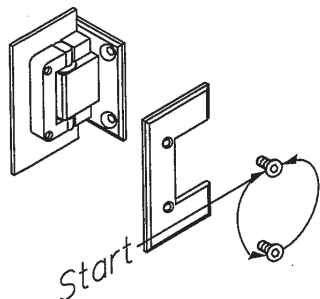

HINGE ASSEMBLY

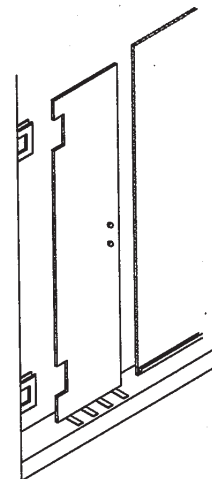
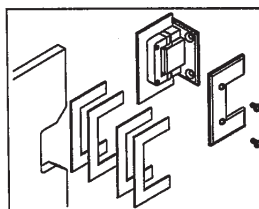

NOTE: REPEAT THE TIGHTENING SEQUENCE AS NEEDED TO ACHIEVE A GOOD HOLD ON THE GLASS.

Installation Instruction

Models: HSD290 (1/2-in), ESD290 (3/8-in) or QSD290 (1/4-in)

Models: HLSD290 (1/2-in), ELSD290 (3/8-in) or QLSD290 (1/4-in)

WITH HEADER, NOTCHED PANEL AND STEP RETURN

6. PLACE 1/4" SETTING BLOCKS INSIDE BOTH BOTTOM CHANNELS. POSITION END PANEL GLASS IN BOTTOM CHANNEL AND WALL CHANNEL. GLASS SHOULD BE PLUMB AND RISE ABOVE THE WALL CHANNEL BY 1/4". POSITION FRONT GLASS PANEL IN BOTTOM CHANNEL WITH THE CORNERS OF THE GLASS BUTTED TOGETHER. CHECK PANELS FOR PLUMB AND MAKE SURE TOP EDGES OF GLASS PANELS ARE ALIGNED. TAPE CORNER OF GLASS TOGETHER TO TEMPORARILY HOLD PANELS IN PLACE FOR HEADER INSTALLATION.

NOTE:

USE TAPE OF SUFFICIENT STRENGTH TO HOLD THE POSITION OF THE GLASS.

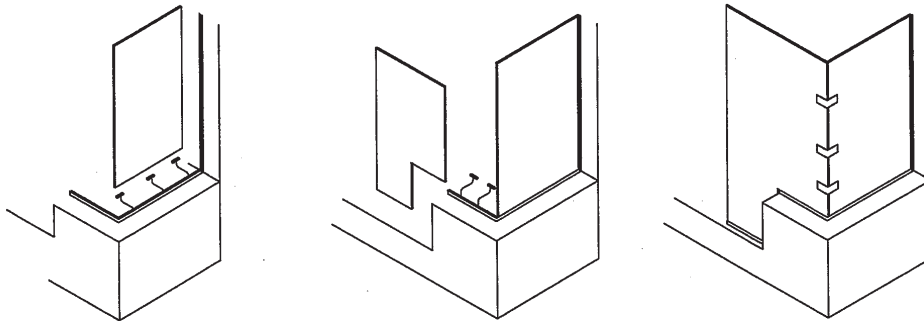

7. (STEP A) MEASURE TOP EDGE OF GLASS FROM WALL TO TO CORNER OF GLASS PANELS AND ADD 3/8". MEASURE THE LONG SIDE OF THE HEADER AND CUT HEADER AT SQUARE END. PLACE TWO SMALL PIECES OF GLAZING VINYL ON TOP EDGE OF GLASS. POSITION HEADER DOWN OVER THE TOP EDGE OF THE END PANEL.

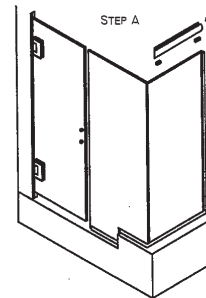

(STEP B) MEASURE FROM OPPOSITE WALL TO THE CORNER OF THE PANEL HEADER. CUT FRONT HEADER TO LENGTH AT SQUARE END. PLACE TWO SMALL PIECES OF GLAZING VINYL OVER THE TOP EDGE OF THE FRONT GLASS PANEL. POSITION FRONT HEADER DOWN OVER TOP EDGE OF PANEL GLASS. CHECK THE HEADERS TO MAKE SURE THEY ARE LEVEL.

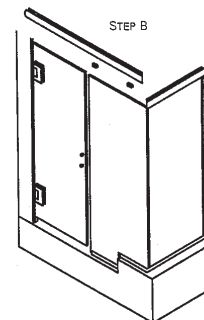

(STEP C) PLACE THE WALL MOUNTING BRACKETS INSIDE THE TOP CHANNEL OF THE HEADER. MARK THE HOLE LOCATIONS ON THE WALL. REMOVE THE HEADERS AND ASSEMBLE WITH THE CORNER BRACKET. SECURE THE BRACKET TO THE HEADER WITH 5/32" ALLENHEAD WRENCH. DRILL 3/16" HOLES AT WALL MOUNTING LOCATIONS AND INSERT PLASTIC ANCHORS. CUT FULL LENGTH GLAZING VINYL FOR THE TOP OF THE GLASS PANELS AND REINSTALL HEADER ASSEMBLY. SECURE THE MOUNTING BRACKETS TO THE WALL WITH #8X1-1/2" SCREWS. SECURE THE MOUNTING BRACKETS TO THE HEADER BY TIGHTENING THE SET SCREWS WITH THE 5/32" ALLENHEAD WRENCH.

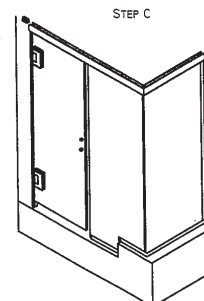

Installation Instruction

Models: HSD290 (1/2-in), ESD290 (3/8-in) or QSD290 (1/4-in)

Models: HLSD290 (1/2-in), ELSD290 (3/8-in) or QLSD290 (1/4-in)

WITH HEADER, NOTCHED PANEL AND STEP RETURN

8. INSTALL THE HANDLE ASSEMBLY THROUGH HOLES IN DOOR GLASS USING THE PLASTIC SHIMS AND BUSHINGS.

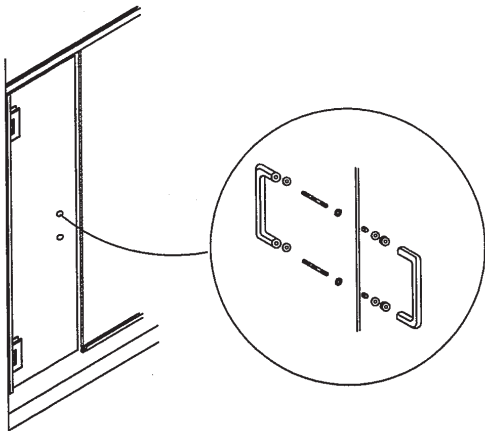

9. MEASURE ABOVE DOOR BETWEEN THE HINGE JAMB AND THE PANEL. CUT THE CROWN FILLER TO SIZE AND SNAP INTO THE BOTTOM CHANNEL OF THE HEADER. MEASURE WIDTH OF DOOR GLASS AT BOTTOM EDGE. CUT THE DOOR BOTTOM SEAL TO SIZE AND INSTALL ON BOTTOM EDGE OF DOOR GLASS.

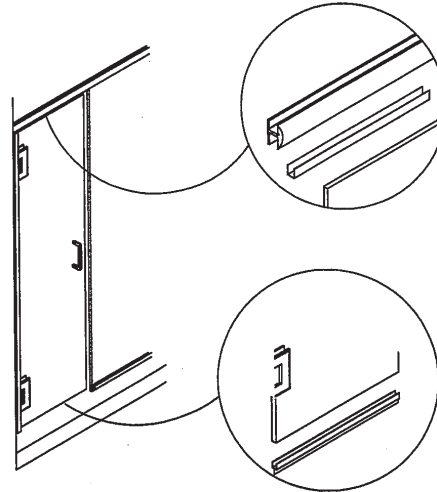

10.

— Wet/Silicon Glaze Option

Choose Glazing Method

INSERT CENTERING CLIPS INTO THE BOTTOM AND WALL CHANNELS. ENSURE SETTING BLOCKS ARE IN CURB AS WELL. RUN A CONTINUOUS BEAD OF SILICONE ON BOTH SIDES OF THE STATIONARY PANELS WHERE THE GLASS AND U-CHANNEL MEET. RUN A SMALL BEAD OF SILICONE ALONG THE INSIDE CORNER WHERE THE GLASS PANELS BUTT TOGETHER. ALLOW SILICONE TO CURE FOR 24 HOURS BEFORE USING SHOWER.

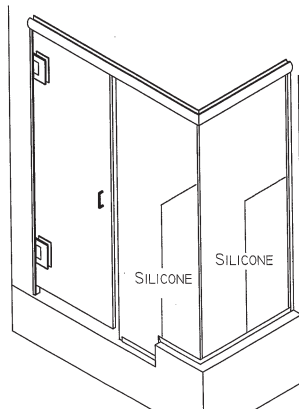

— or Dry Glaze Option

USE SNAP GLAZING VINYL ON BOTH SIDE OF THE GLASS TO SECURE THE PANEL INTO POSITION
NOTE: DO NOT USE CENTERING CLIPS IF YOU CHOOSE TO DRY GLAZE THE PANEL