



Installation Instructions for

1/4" Door Models: **SSD180** or **DSD180**

1/4" Semi-Frameless Swing Door with 3/16" 180° Panel (or 2 - 180° Panels: _SD280)

3/16" Door Models: **VSD180** or **CSD180**

3/16" Semi-Frameless Swing Door with 3/16" 180° Panel (or 2 - 180° Panels: _SD280)

FIRST STEPS - Identify the door width and model number of your unit.

- Look on the white shipping label on the outer cardboard box.

- **Door width** is annotated as DW or DWX on the label

DW or DWX = fill-in

- **Model number** on label should correspond to one listed above.
Or look below and identify by **handle type and glass thickness**

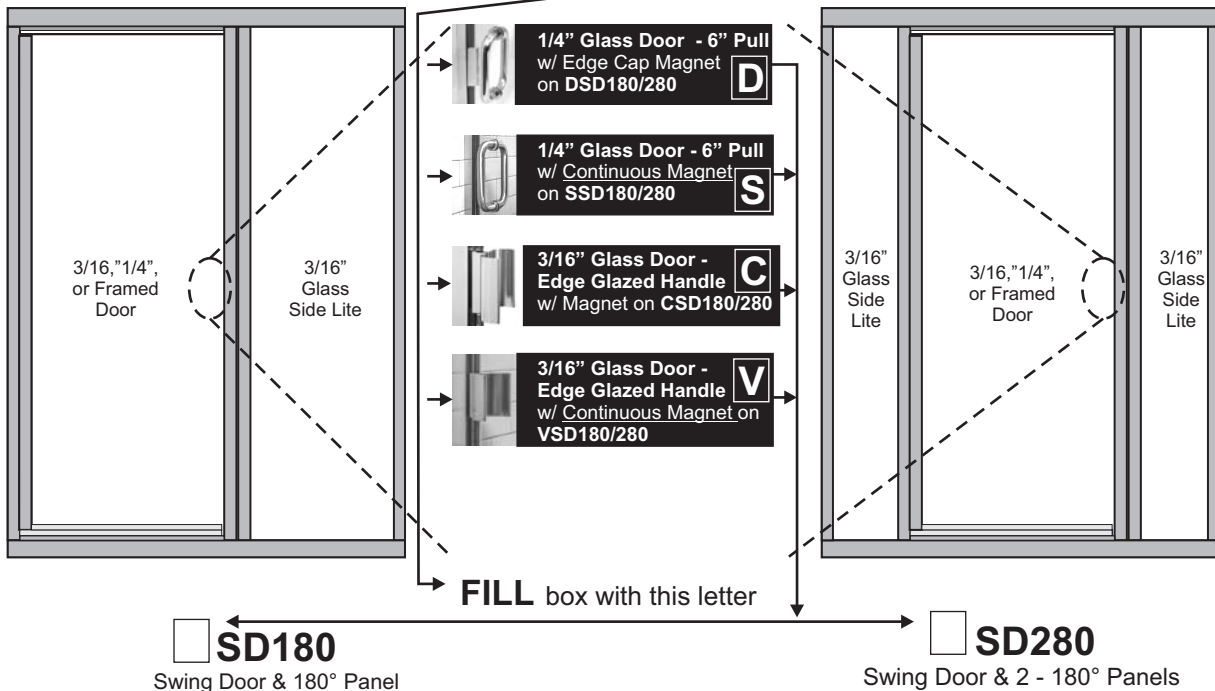

* Please see page 15 if your units has a step up or notched panel

Required Tools

* Pencil or water soluble felt pen

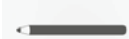

* Hacksaw with 24 tooth blade



* Metal file (smooth sharp edges)



* Tape measure



* Clear 100% Silicone (recommended)



* #2 Phillips Screw driver



* 3/16" drill bit carbide for tile

* #32 Wire Gauge drill bit



* Caulking gun



* Drill, electric or battery



* 4 ft. Level



* Rubber mallet



* Razor knife



* Blue painters tape



READ ENTIRE MANUAL BEFORE INSTALLATION AND OPERATION

Warnings and General Shower Door Information



HEAVY



CAUTION

**SAFETY
WARNINGS:**



SHARP



GLASS FRAGILE



EYEWARE

READ AND FOLLOW INSTRUCTIONS: Failure to follow all instructions, warnings and guidelines may result in serious injury or death, may cause water damage, and will void the terms of your warranty.

General Safety and Installation Policies

Before Installation:

- **Proper Size:** Ensure the enclosure is the proper size for your opening prior to beginning installation.
- **Safe Installation:** Some units may require two or more people to safely install the enclosure properly.
- **Packaging:** It is recommended to retain all packaging and other materials until installation is complete in the event of a return.
- **Inspect:** Installer should inventory all parts or components and inspect them for damage prior to beginning installation.
- **Sharp Edges:** Exposed ends of aluminum and other hard components can be rough, sharp or jagged due to the processes of cutting, drilling, notching, etc. Sharp ends must be deburred, smoothed or rounded by the installer before installation.
- **Safety equipment and tools:** Have all necessary safety equipment (glasses and gloves) and proper tools for the installation. The installer is responsible for determining the correct drill bit(s) for the installation.
- **New Tile:** We recommend that you allow at least 2 days (48 hours) for the tile cement and grout to dry before installing enclosure.

During Installation



- **Proper backing:** Shower doors are heavy. Therefore, glazing channels, fillers, hinges and headers blocks (structural components) should be secured to studs or solid backing beneath the tile or decorative substrate. Fasteners should screw directly into the backing. Wall anchors are provided primarily to separate screws from tile to reduce the possibility of cracking.

- **Tempered glass:** Glass can break. Shower door panels are tempered to ASTM C1048 specifications as required by building codes. Glass is tempered to greatly increase its strength and to make it fragment into smaller and lighter pieces reducing the possibility of injury in the event that the glass does break. Tempered glass will break and may cause bodily injury if you attempt to cut, drill, mill or alter it in any way. Care must be taken when handling tempered glass. Pay special attention to protect all edges of the glass from contact with hard surfaces.
- **Horizontal surfaces and installation holes:** Avoid drilling into the horizontal surfaces of tubs or showers unless it is required for the structural integrity of the unit. If you drill into horizontal surfaces, always generously caulk the holes, anchors, screws and on top of the screw head. If this is not done, or is done improperly, water damage can occur under the tile or substrate.
- **Weep holes in horizontal channels:** Drilling 3/8" weep holes on the inside of horizontal channels is recommended to allow any moisture build-up inside a channel to exit the channel. Due to varying installation conditions and installer's/owner's personal preference, however, we do not drill them in the factory.
- **Sliding and swinging glass doors:** A door may be improperly installed if it hits or scrapes against bathroom obstructions (toilets or cabinets) or any metal or glass components of the shower door itself. This could lead to glass breakage or serious injury. The installer must correct the deficiencies before allowing the door to be used.
- **Surface conditions:** Most shower door designs allow for out-of-square or unlevel installation. Generally, any outage more than 3/8" that was not identified during the ordering process is outside of these allowances and can result in an improper installation.

Caulking/Siliconing the Unit:

- Always clean all contact surfaces before caulking and use a high grade 100% silicone for best results.
- After installation, at a minimum, caulk the entire outside perimeter of the unit where the unit touches walls, sills, and step-ups, etc. Also caulk any vertical joints between metal components where water build-up inside of the channels could leak out.

After Installation:

- **Curing times:** Adhere to manufacturers' recommended curing times for VHB tapes, silicones and any other adhesives, coatings or chemicals used during installation. Unless otherwise stated, it is recommended to wait 72 hours before using the enclosure.
- **Normal wear and tear:** Although these enclosures are designed to last for years, certain items (such as the polycarbonate seals and door sweeps) may need to be replaced as they show signs of aging and wear.

General Disclaimers

- **Shower Doors are not watertight:** Consumers should understand that a shower door is not watertight. The amount of water that can escape your shower can vary greatly based on shower/tub size, configuration of shower head(s), type of thresholds and drains and by the type of shower door itself. Heavy glass units with no or limited vinyl seals, for example, can allow water to escape under normal conditions. Doors with more metal and seals generally provide more water protection. Excessive water pressure or directing shower heads or hand held sprays directly at doors or joints is not a normal shower conditions and can result in leaks.
- **Towel bars, handles and accessories** are in no way considered to be grab bars or other bracing or fall prevention mechanisms. The intent of these accessories is to facilitate proper operation or enhance the esthetics and functionality of the unit.

Owners Manual:

Refer to your Owners Manual for general installation and cleaning and care instructions. If a copy of the Owners Manual was not included, you can download one on the RESOURCES page of our website.

Questions or Comments:

1-800-843-3332

Frame Parts and Stationary Panel for

 **SD180** (parts are common for all "180" units)

Figure 1 - Exploded View __SD180 only



Parts List

ITEM	PART #	DESCRIPTION	QTY
1	EX.1171	STALL HEADER	1
2	EX.1271	STALL CURB	1
3	EX.1072	HEADER/CURB FILLER	2
4	EX.1173	180° POST	1
5	EX.1268	JAMB FILLER/WALL CHANNEL	2
6	GLASS	3/16" GLASS SIDE LITE PANEL	1
7	VN.4031	SNAP - VERTICAL VINYL	4
8	VN.4026	VS-14 HORIZONTAL VINYL	4
9	BP.3027	#8 X 1-1/2 FHPSMS	6
10	BP.3027	3/16 WALL ANCHOR	6

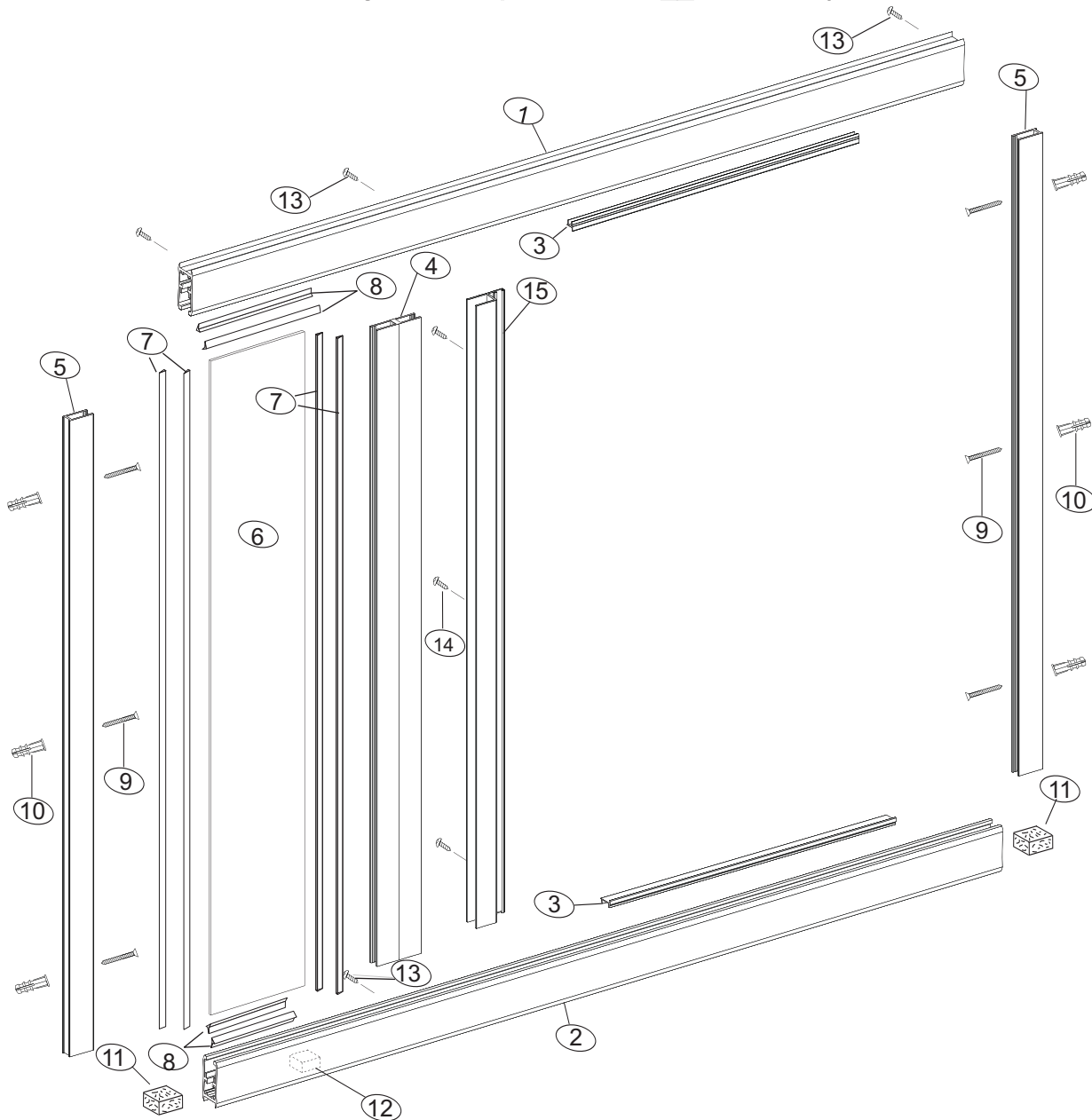
ITEM	PART #	DESCRIPTION	QTY
11	BP.3031	FOAM CURB PLUGS	2
12	BP.3031	SETTING BLOCKS	1
13	BP.3031	6 X 3/8 PHPSMS	10
14	BP.3031	8 X 1/2 PHPSMS TEK	6
15	EX.1193	LATCH JAMB	1
16	VN.4033	VERTICAL GLAZING VINYL*	4

*Optional for 1/4" glass

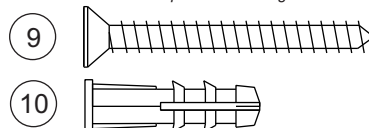

Extra screws may be provided for your convenience

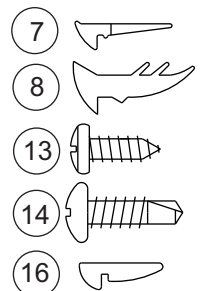

Door assy on following pages

Frame Parts and Stationary Panels for

 **SD280** (parts are common for all "280" units)

Figure 1 - Exploded View __SD280 only



Parts List

ITEM	PART #	DESCRIPTION	QTY
1	EX.1171	STALL HEADER	1
2	EX.1271	STALL CURB	1
3	EX.1072	HEADER/CURB FILLER	2
4	EX.1173	180° POST	2
5	EX.1268	JAMB FILLER/WALL CHANNEL	2
6	GLASS	3/16" GLASS SIDE LITE PANEL	2
7	VN.4031	SNAP - VERTICAL VINYL	8
8	VN.4026	VS-14 HORIZONTAL VINYL	4
9	BP.3027	#8 X 1-1/2 FHPSMS	6
10	BP.3027	3/16 WALL ANCHOR	6

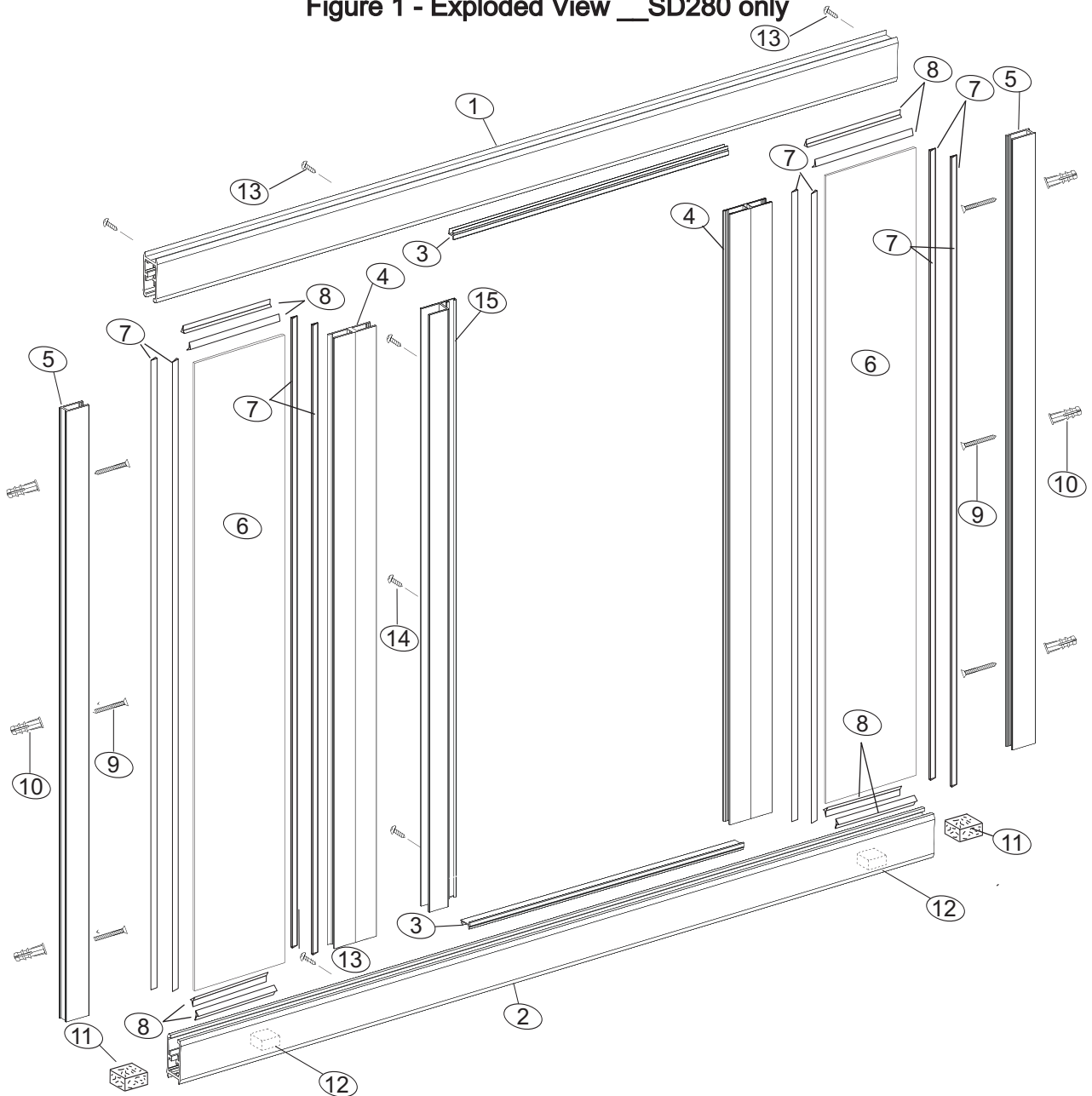
ITEM	PART #	DESCRIPTION	QTY
11	BP.3031	FOAM CURB PLUGS	2
12	BP.3031	SETTING BLOCKS	2
13	BP.3031	6 X 3/8 PHPSMS	10
14	BP.3031	8 X 1/2 PHPSMS TEK	8
15	EX.1193	LATCH JAMB	1
16	VN.4033	VERTICAL GLAZING VINYL*	4

*Optional for 1/4" glass

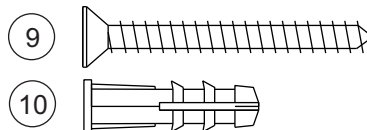

Extra screws may be provided for your convenience

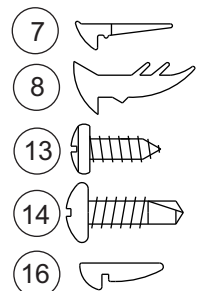

Door assy on following pages

Installation Instructions

SD180 or SD280

STEP 1 - Curb Installation (#1)

- * Measure the wall to wall where you want the center of the unit to be installed, subtract 1/16" from this.
- * Mark location for reference.
- * Cut the Stall Curb (ITEM #2) to this length.
- * Insert at least 2 setting blocks (ITEM #12) in the curb underneath where each side lite panels will rest.
- * Set the curb in place centered over where you measured, secure with blue tape.
- * Verify weep holes are oriented to the inside of shower.
- * Do not screw the curb to threshold.
- * Insert foam plug (ITEM #11) into each end of the Stall Curb and recess 1/8". Fill 1/8" void with silicone.

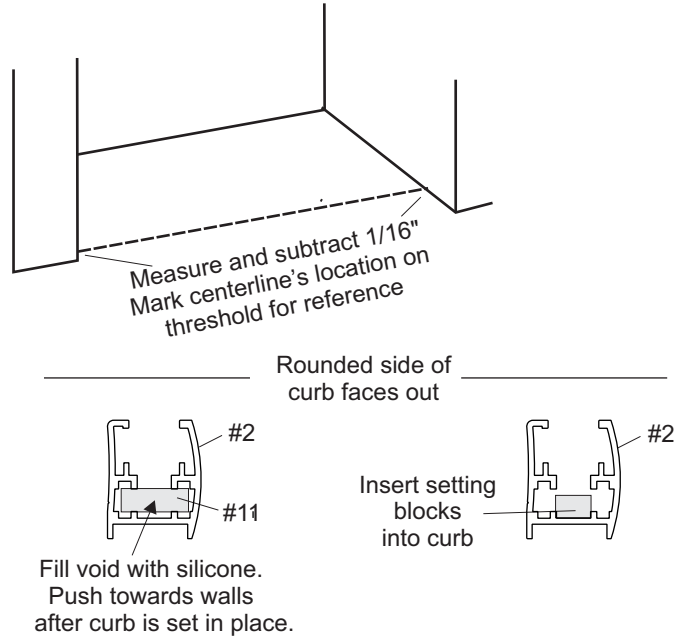

STEP 2 - Wall Channel (#5)

- * Insert Wall Channel (ITEM #5) into curb, on side of fixed panel. Plumb channel with a level.
- * Mark the hole locations onto the wall. Remove the channel.
- * Drill marked locations with 3/16" drill bit
- * Insert 3 Wall Anchors (ITEM #10).
- * Re-insert channel and secure with 3 screws (ITEM #9).

SD280 Steps: Repeat above step on the opposite wall if installing a SD280

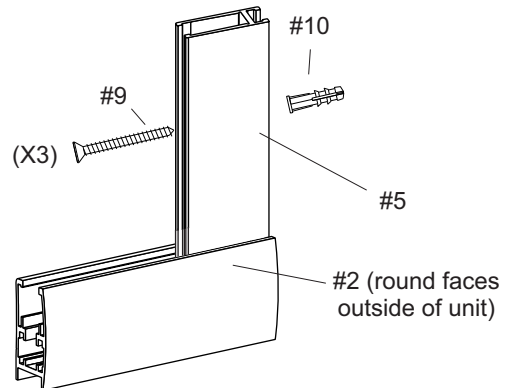

STEP 3 - 180° Post(s) & 3/16" Fixed Panel(s):

SD180 Steps (skip to next page if SD280)

- * Set 3/16" Glass Panel into Curb and Wall Channel.
- * NOTE: If patterned or frosted glass is used, ensure that the rough side faces outward.
- * Insert the 180° Post (ITEM #4) into the Stall Curb and over the edge of the Side Lite Panel
- * Subtract 3/4" from DW or DWX length.
- * Mark this dimension onto the Stall Curb measuring from the door side wall.
- * Move the leading edge of the 180° Post to this mark
- * Temporarily hold the post and glass in place by glazing the top 1" – 2" of the panel into the channels. This is done by inserting Snap Vinyl (ITEM #7) between glass and channel. Do not cut the vinyl at this time.

DW or DWX = from pg 1

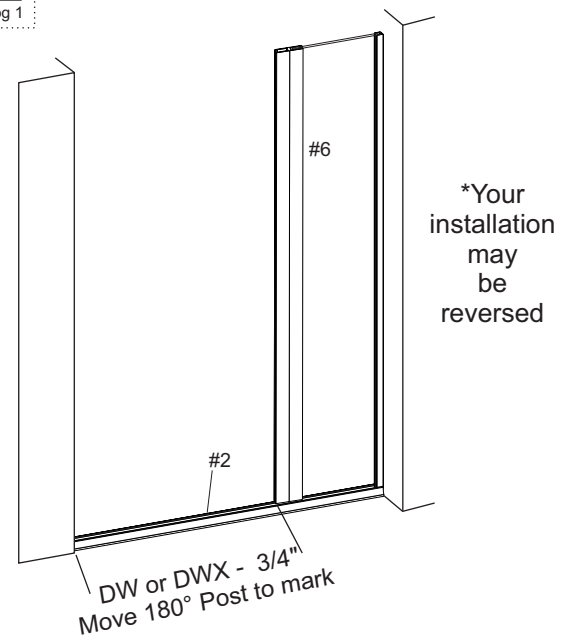

Installation Instructions

SD180 or SD280

STEP 3 - 180° Posts & 3/16" Fixed Panels:

SD280 Steps:

- * Insert the Side Lite Panels (ITEM #6) into the Stall Curb and Wall Channels, resting on a Setting Block
- * NOTE: If patterned or frosted glass is used, ensure that the rough side faces outward.
- * Insert the 180° Posts (ITEM #4) into the Stall Curb and over the edge of the Side Lite Panels.
- * Measure and mark the center of the Stall Curb
- * Subtract 1 3/4" from DW or DWX length.
- * Center this dimension over the center of the Stall Curb and mark it onto the curb
- * Bring the leading edges of the 180° Posts to these marks See (FIG. #3) for detail.

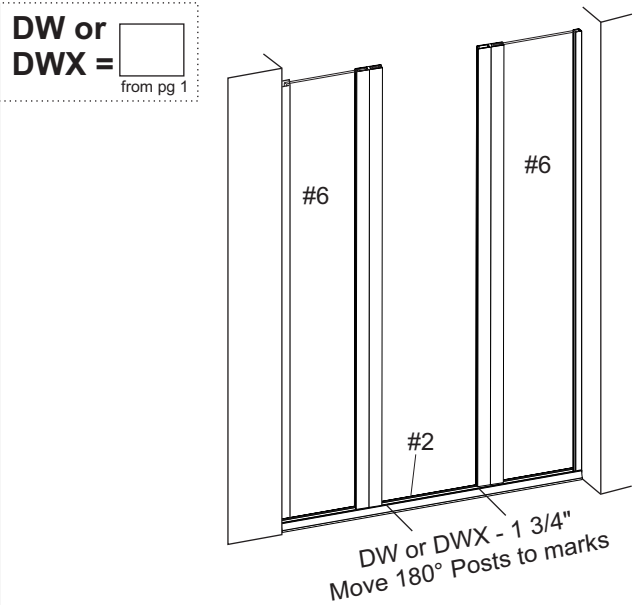

STEP 4 - Stall Header

- * Measure wall to wall at the top of the vertical posts.
- * Subtract 1/16" and cut Stall Header (ITEM #1) to length.
- * Set header over the top of the vertical posts. Verify that the bottom(s) of the 180° Post(s) have not moved from their marks
- * Tap the top(s) of the 180° Posts into a plumb position
- * From the inside of the shower, attach the header by drilling through the header into the verticals with a #32 wire gauge drill bit. The glass panels should be tilted out of the way while drilling holes.
- * Secure header with #6 X 3/8 PHPHSMS (ITEM #13).
- * Secure the curb at the 180° Post(s) using the same method.

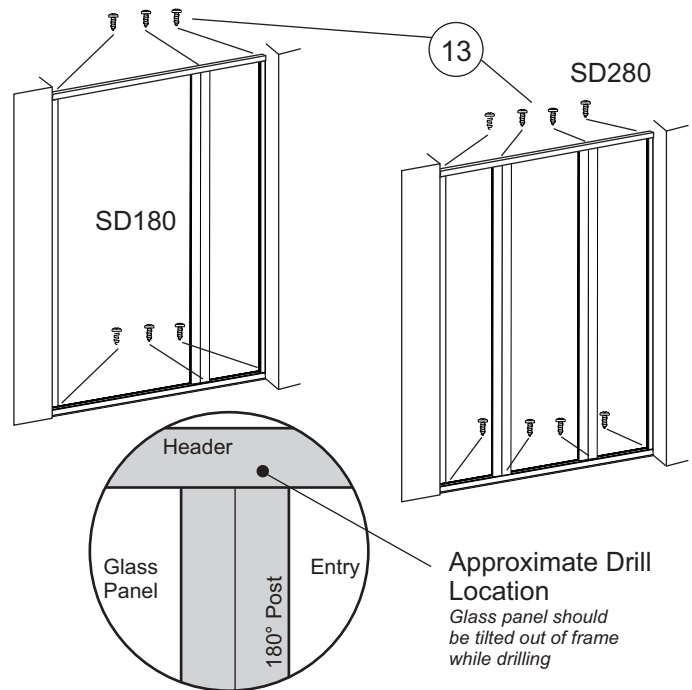

STEP 5 - Vinyl Glaze 3/16" Glass Side Lite Panel(s)

- * Center a Side Lite Pane(s) between its posts
- * Glaze vertical post(s) and wall channel(s) with Glazing Vinyl (ITEM #7).
- * Glaze the top and bottom of the panel with 4 - VS-14 Glazing Vinyl (ITEM #8).
- * Refer to Exploded views on pgs 4 and 5 for glazing vinyl types and proper locations

(Special: Refer to Pg 16 for glazing 1/4" side lite panels for some D and S units with special pattern glass)

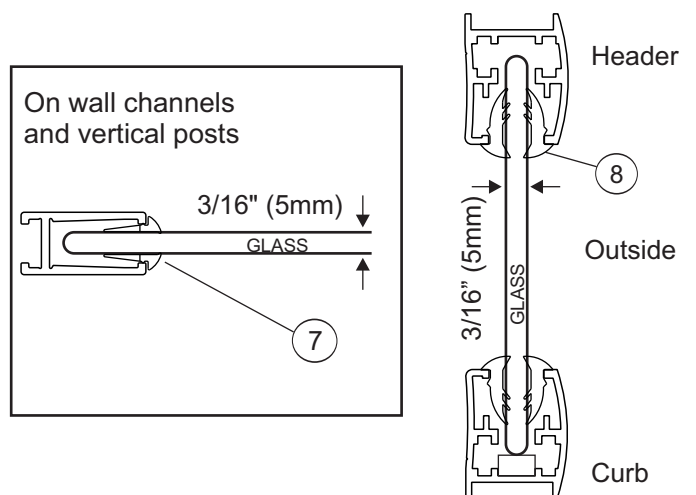

Installation Instructions

SD180 or SD280



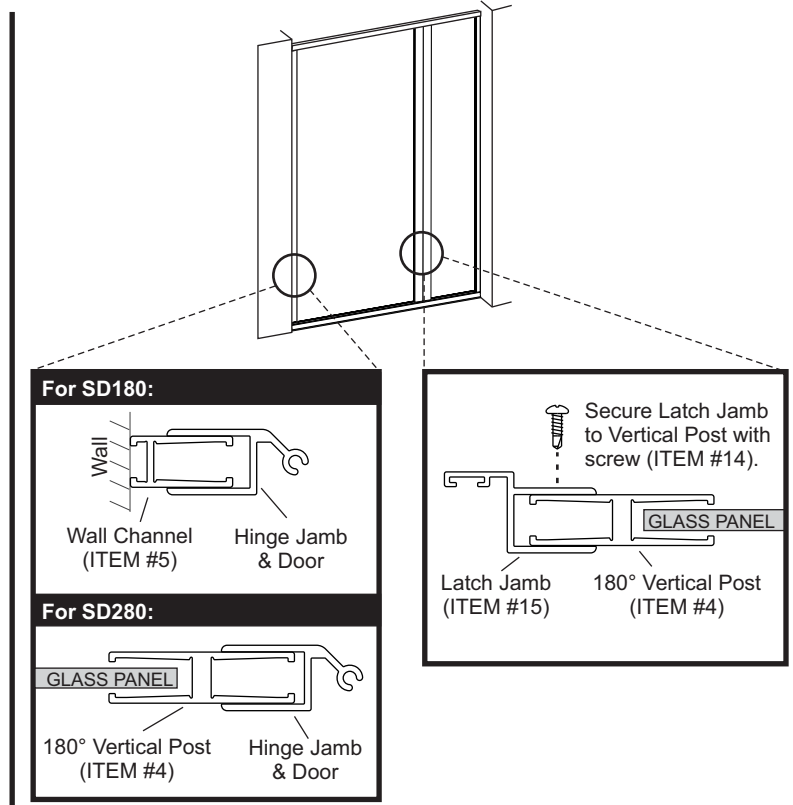

STEP 6 - Latch and Door Installation

- * Set the Latch Jamb (ITEM #15) in place over the appropriate vertical post, but do not secure at this time. Orient the door so that it will open outwards and slide Hinge Jamb (which is connected to the door) over the opposite post.
- * Adjust the Hinge and latch jamb somewhat equally off their respective vertical posts, (Primary Adjustment).
- * Adjust door to ensure the top of the door is parallel with the bottom of the header.
- * From the inside of the shower, drill the top hole on the Hinge Jamb into the vertical post with a #32 wire gauge drill bit.
- * Secure with a #8 X 1/2 PHPHSMS TEK (ITEM #14). Re-check the door alignment and repeat the procedure for the middle and bottom screws.



Door installation is specific to the model you purchased!

Find your model and proceed to the appropriate page

D		Model Number: <u>DSD180/280</u> 1/4" Glass Door - 6" Pull w/ Edge Cap Magnet	➔ Page 9
S		Model Number: <u>SSD180/280</u> 1/4" Glass Door - 6" Pull w/ <u>Continuous Magnet</u>	➔ Page 10
C		Model Number: <u>CSD180/280</u> 3/16" Glass Door - Edge Glazed Handle w/ Magnet	➔ Page 11
V		Model Number: <u>VSD180/280</u> 3/16" Glass Door - Edge Glazed Handle w/ <u>Continuous Magnet</u>	➔ Page 12



Installation Instructions for

Model Number: **DSD180/280**
1/4" Glass Door - 6" Pull w/ Edge Cap Magnet

Step 7 - Handle (multiple styles)

* Dis-assemble handle assembly then reverse the procedure and install into the 1/2" handle holes in the door panel.

Step 8 - Magnetic Catch

- * Dry fit magnet catch over the edge of the glass and line it up with the steel plate in the latch jamb.
- * Mark top and bottom of the Magnet latch onto edge of glass.
- * Inject a small amount of silicone into the magnet latch.
- * Tap in place over the glass edge lined up with the location marks you made earlier.
- * Use Painters tape to hold Magnet latch in place until it dries.

Step 9 - Adjust and Secure Latch Jamb

* Adjust the reveal on the latch jamb so it is the same top to bottom. Make sure the the steel plate is still lined up with the Magnet latch and secure the latch jamb with 3 - #8 X 1/2" PH TEK #14 screws.

Step 10 - Drip Assembly

- * Measure the distance from the edge of the glass to the edge of the hinge rail as shown below right.
- * Both ends of the Bottom Sweep are notched so that one of the notches will seal under the hinge rail.
- * Identify which notched end you are going to keep and cut the drip assembly to length. Notch the cut end as shown.
- * Fit over the bottom edge of the door panel and adjust for height.

Handle Assembly (#19)

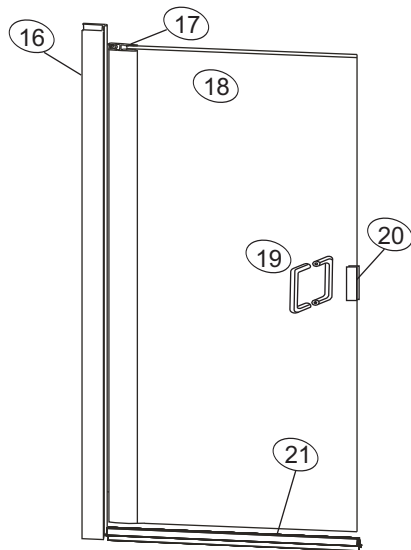
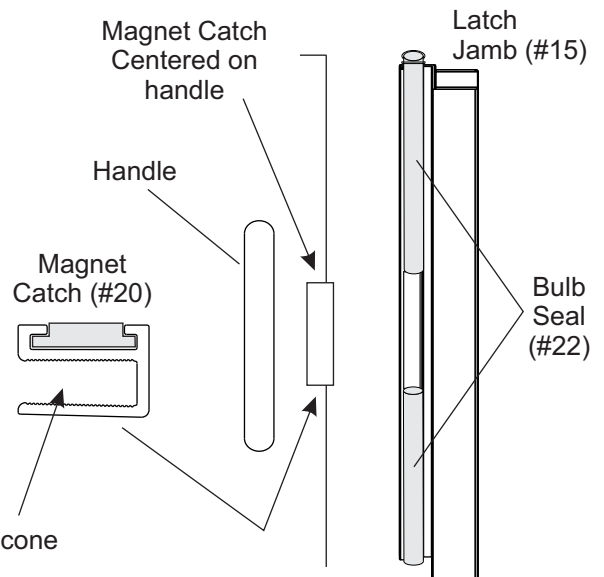
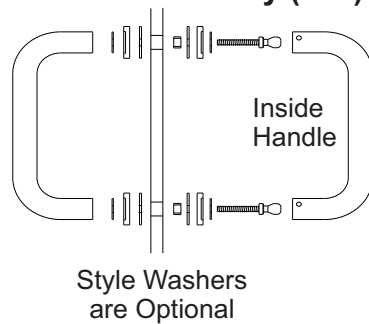

ITEM	PART #	DESCRIPTION	QTY
16	EX.1165	Hinge Jamb	1
17	EX.1466	Hinge Rail	1
18		1/4" Glass Panel	1
19	HA.2701	Handle	1
20	BP.3701	Over Edge Magnet	1
21	VN.4062	Bottom Sweep	1
22	VN.4002	Bulb Seal	1

DRIP ASSEMBLY DETAIL

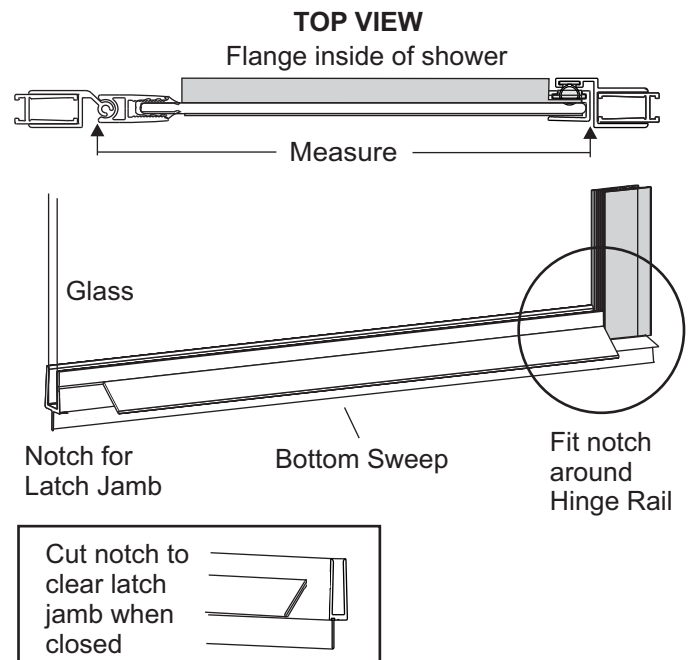

Proceed Step 11 on page 13 →



Installation Instructions for

Model Number: **SSD180/280**
 1/4" Glass Door - 6" Pull w/ Continuous Magnet

Step 7 - Handle (multiple styles)

* Dis-assemble handle assembly then reverse the procedure and install into the 1/2" handle holes in the door panel.

* Step 8 - Drip Assembly

- * Measure the distance from the edge of the glass to the edge of the hinge rail as shown below right.
- * Both ends of the drip assembly are notched so that one of the notches will seal under the hinge rail.
- * Identify which notched end you are going to keep and cut the drip assembly to length. Notch the cut end as shown.
- * Fit over the bottom edge of the door panel and adjust for height.

Step 9 - Apply Adhesive Magnet Strip

- * Remove the adhesive magnet off of the latch jamb magnet and note that the index grooves are on the same side.
- * Keep indexes on the same side, peel off the red backing and apply the magnet to the vertical edge of the door panel. Trim at the top of the glass and trim the bottom off at the top of the Drip Assembly.

Step 10 - Adjust and Secure Latch Jamb

- * Adjust the latch reveal so that it is even all the way down and centered over the magnet on the door.
- * Secure the latch jamb with 3 - #8 X 1/2 PH TEK screws.
- * If the magnets repel each other, remove and reverse the magnet in the latch jamb.

Handle Assembly (#29)

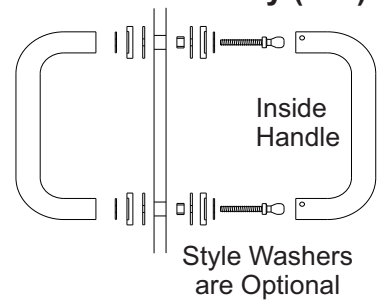

BOTTOM SWEEP DETAIL

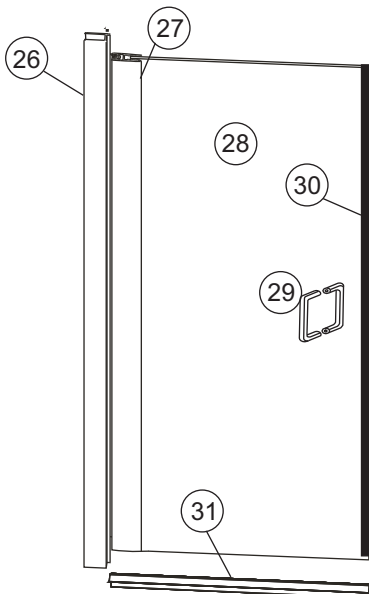

ITEM	PART #	DESCRIPTION	QTY
26	EX.1165	Hinge Jamb	1
27	EX.1466	Hinge Rail	1
28		1/4" Glass Panel	1
29	HA.2701	Handle	1
30	VN.4102	Adhesive Magnet	1
31	VN.4062	Bottom Sweep	1

DRIP ASSEMBLY DETAIL

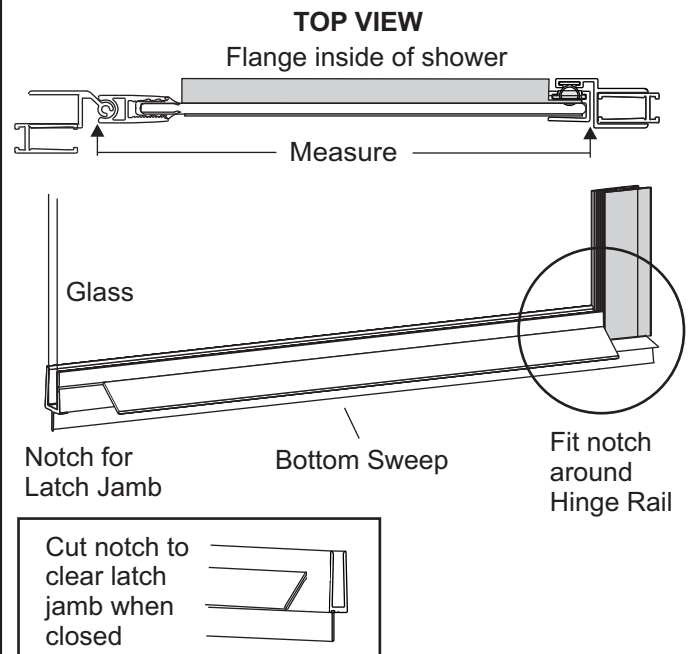

Proceed Step 11 on page 13



Installation Instructions for

Model Number: **CSD180/280**
3/16" Glass Door - Edge Glazed Handle w/ Magnet

Step 7 - Magnetic Handle

- * Dry fit the magnet handle over the edge of the glass and line it up with the steel plate in the latch jamb.
- * Mark the top and bottom of the Magnet latch onto the glass edge.
- * Lay the handle vinyl in place over the edge of the of the door panel, and over the top and bottom marks for the handle location. Tap handle in place over the handle vinyl, lined up with the location marks you made earlier.
- * Use a razor knife to trim the excess handle vinyl.

Step 8 - Adjust and Secure Latch Jamb.

- * Adjust reveal on the latch jamb so it is the same top to bottom
- * Make sure the steel plate is still lined up with the Magnet latch and secure the latch jamb with 3 - #8 X 1/2" PH TEK screws.

Step 9 - Drip Assembly

- * Measure the distance from the edge of the glass to the edge of the hinge rail as shown below right.
- * Both ends of the drip assembly are notched so that one of the notches will seal under the hinge rail.
- * Identify which notched end you are going to keep and cut the drip assembly to length. Notch the cut end as shown.
- * Fit over the bottom edge of the door panel and adjust for height.

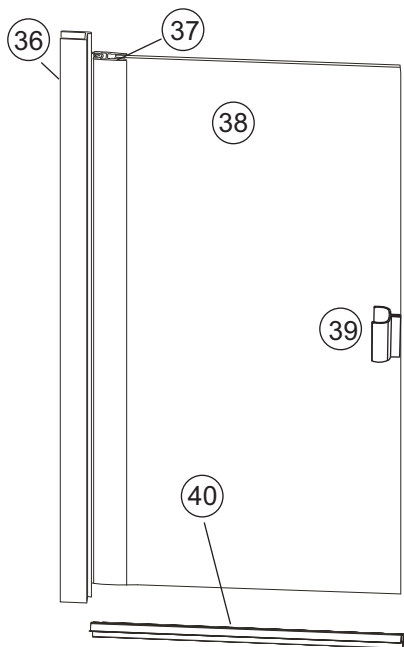
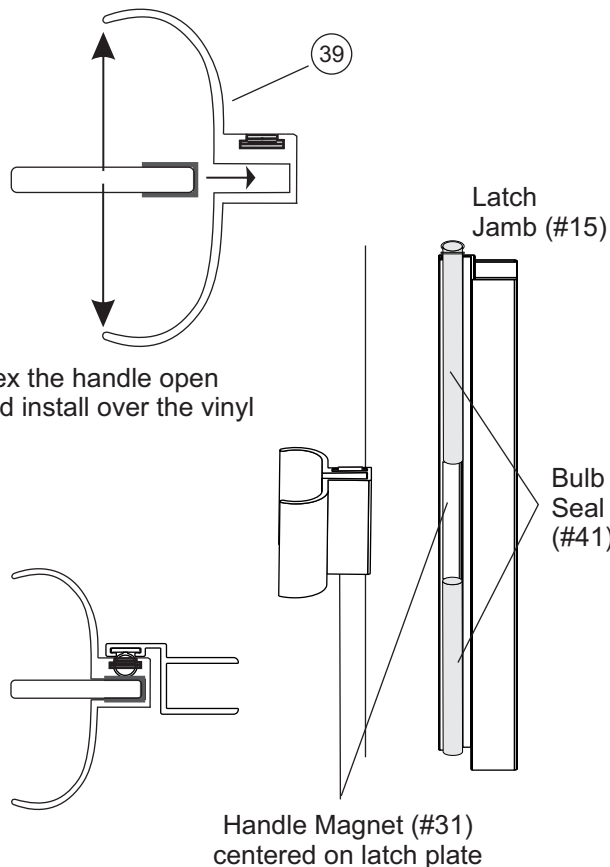

DRIP ASSEMBLY DETAIL

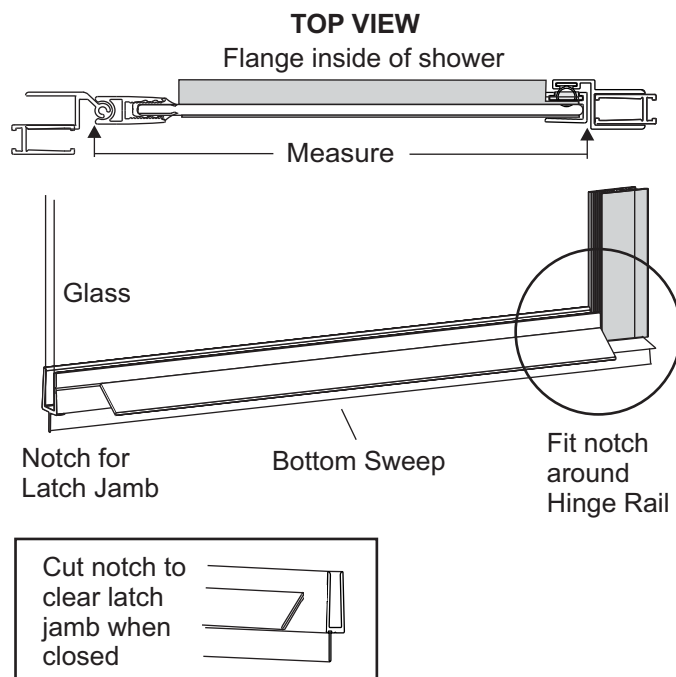

ITEM	PART #	DESCRIPTION	QTY
36	EX.1165	Hinge Jamb	1
37	EX.1466	Hinge Rail	1
38		3/16" Glass Panel	1
39	BP.3021	Handle	1
40	VN.4082	Bottom Sweep	1
41	VN.4002	Bulb Seal	1



Installation Instructions for

Model Number: **VSD180/280**
3/16" Glass Door - Edge Glazed Handle w/ Continuous Magnet

Step 7 - Handle

- * Dry fit the handle over the edge of the glass and line it up with the vertical centerline of the door panel.
- * Mark the top and bottom of the handle onto the glass edge.
- * Lay the handle vinyl in place over the edge of the of the door panel, and over the top and bottom marks for the handle location. Tap handle in place over the handle vinyl, lined up with the location marks you made earlier.
- * Use a razor knife to trim the excess handle vinyl.

Step 8 - Drip Assembly

- * Measure the distance from the edge of the glass to the edge of the hinge rail as shown bottom right.
- * Both ends of the drip Bottom Sweep are notched so that one of the notches will seal under the hinge rail.
- * Identify which notched end you are going to keep and cut the drip assembly to length. Notch the cut end as shown.
- * Fit over the bottom edge of the door panel and adjust for height.

Step 9 - Adhesive Magnet Strip

- * Remove the adhesive magnet off of the latch jamb magnet and note that the index grooves are on the same side.
- * Keeping the indexes on the same side, peel off the red backing and apply the magnet to the vertical edge of the door panel.
- * Trim at the top of the glass and at the top of the Handle.
- * Take a second piece of adhesive magnet and apply it from the bottom of the handle to the top of the drip assembly.

Step 10 - Adjust and Secure Latch Jamb

- * Adjust reveal on the latch jamb so it is the same top to bottom.
- * Make sure Handle is centered over the latch jamb magnet.
- * Secure latch jamb with 3 - #8 X 1/2" PH TEK screws.

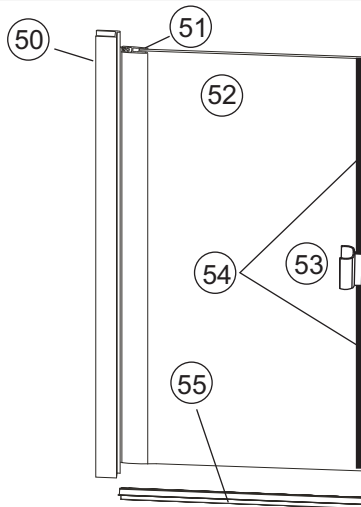
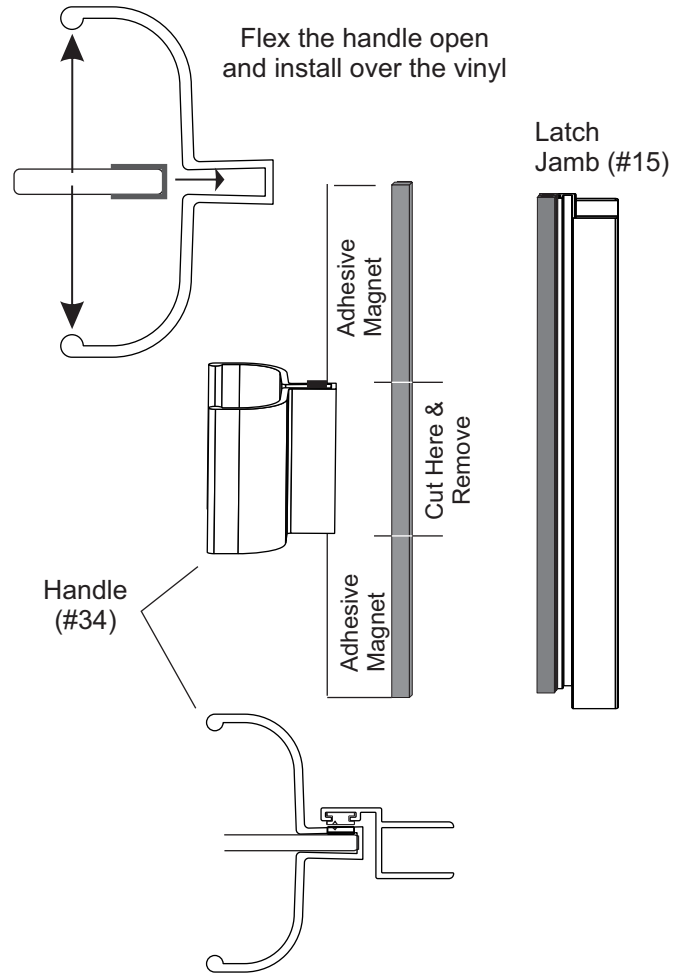

ITEM	PART #	DESCRIPTION	QTY
50	EX.1165	Hinge Jamb	1
51	EX.1466	Hinge Rail	1
52		3/16" Glass Panel	1
53	BP.3019	Handle	1
54	VN.4102	Adhesive Magnet	2
55	VN.4062	Bottom Sweep	1

DRIP ASSEMBLY DETAIL

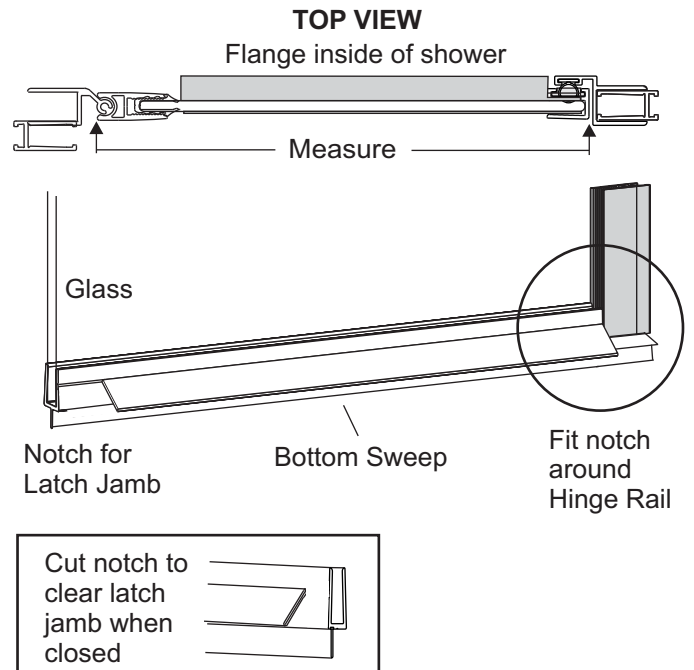

Proceed Step 11 on page 13 →

Installation Instructions

SD180 or SD280

STEP 11 - Header and Curb Fillers

- * With the door in the closed position, measure between the Hinge Jamb and Latch Jamb at the bottom of the door opening (on top of the Stall Curb).
- * Cut one Curb Filler (ITEM #3) to this length. Snap the filler into place in the curb with the vertical water dam of the part to the outside.
- * Seal each end with sealant.
- * Repeat this procedure for the top for the Header Filler (no sealant required).

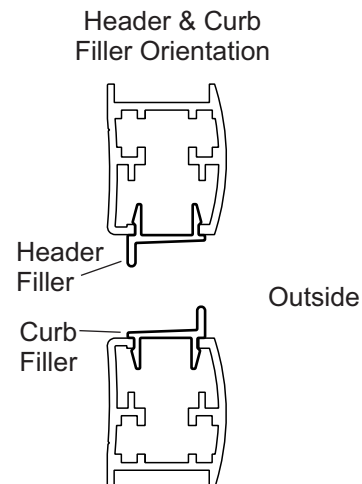
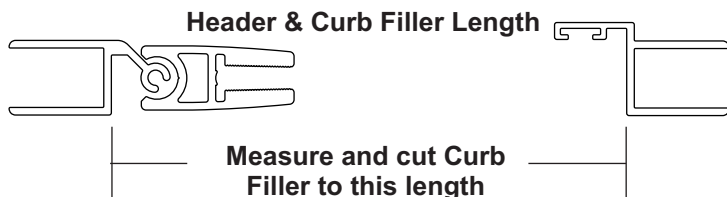

STEP 12 - Silicone Sealant on Outside Perimeter

- * Run a bead of 100% silicone sealant the full length on the outside of the shower where the shower door framing meets the walls and threshold.
- * Allow 24 hours for silicone to cure before using your shower.

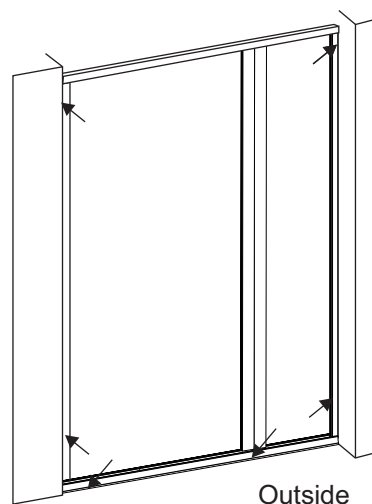

Installation Complete!

Thank you for choosing this great product!

Please refer to your Owner's Manual for Warranty Registration and Cleaning and Care Instructions

Questions or Comments:

1-800-843-3332

Special Notes

Step-up or Notched Panel Installation

These steps should be done in conjunction with the main installation instructions:

1. Insert Foam plugs (#11) and setting blocks (#12) into Stall Curb A as outlined in Step 1 on page 6
2. Set Stall Curb onto centerline. Hold with painters tape.
3. Slide Wall Channel B into C and set into curb and against buttress face. Plumb with a level before aligning remaining pieces.
4. Dry fit Panel Sill D INTO B, then E at the back wall.
5. Plumb E with a level and secure to wall.
6. Reset the Panel Sill D into Wall channel E.
7. Remove post combination B/C.
8. insert setting blocks and Set buttress panel into place.
9. Reinstall post B/C over glass edge
10. Continue with step one on Page 5 to set the curb.

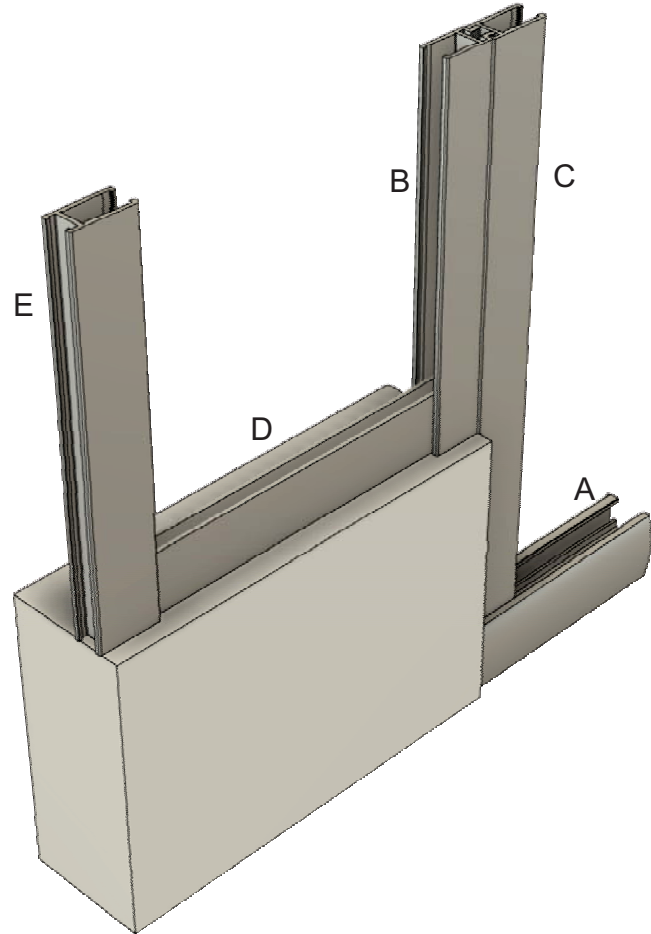

These steps should be done in conjunction with the main installation instructions:

1. Insert Foam plugs (#11) and setting blocks (#12) into Stall Curb A as outlined in Step 1 on page 6
2. Set Stall Curb onto front centerline. Hold with painters tape.
3. Dry fit Panel Sill B C and D
5. Plumb D with a level and secure to wall.
6. Reset the Panel Sill C and B. Secure B to buttress face.
7. 8. insert setting blocks and Set buttress panel into place.
9. Install post E over glass edge. Hold in place with a couple of pieces of glazing vinyl.
10. Continue with step one on Page 6 to set the curb.

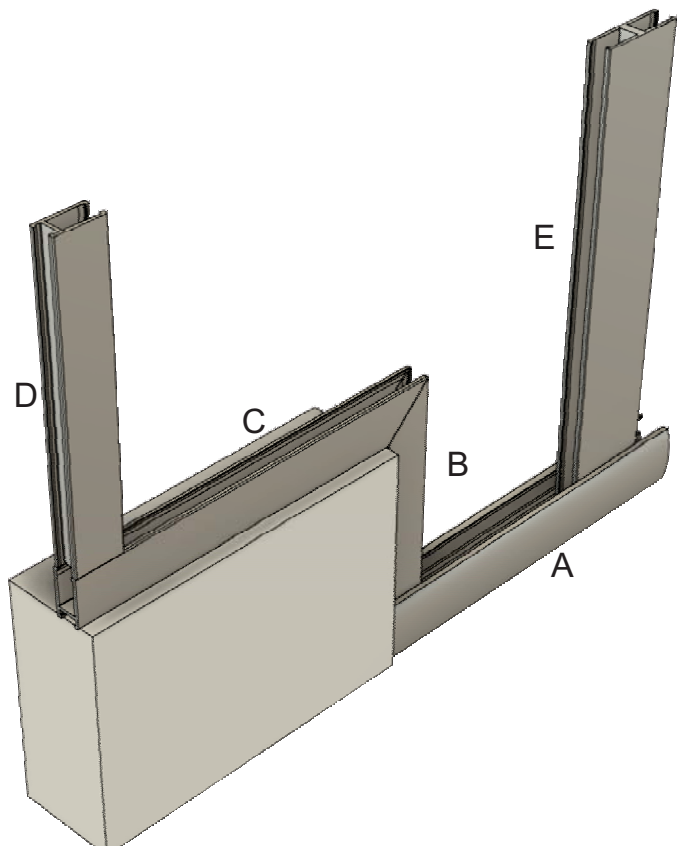

Special Notes

1/4" Thick Sidelite Glass

D and S Units with Special Pattern Glass:

* Some pattern glass does not come in 3/16" thickness for the side lite panels.

* Therefore, when certain glass types are ordered, D and S models must use 1/4" for the side lites.

* This requires a different glazing vinyls and the use of silicone on the inside vertical joints (pictured to the right).

