

Installation Instructions for the Estate Collection

Model: ESE180 / ETE180 (two panel sliding enclosure w/in-line pa

MM.5018

Rev. Date: 01-14-25



FIG. #1 - Shower Door Assembly

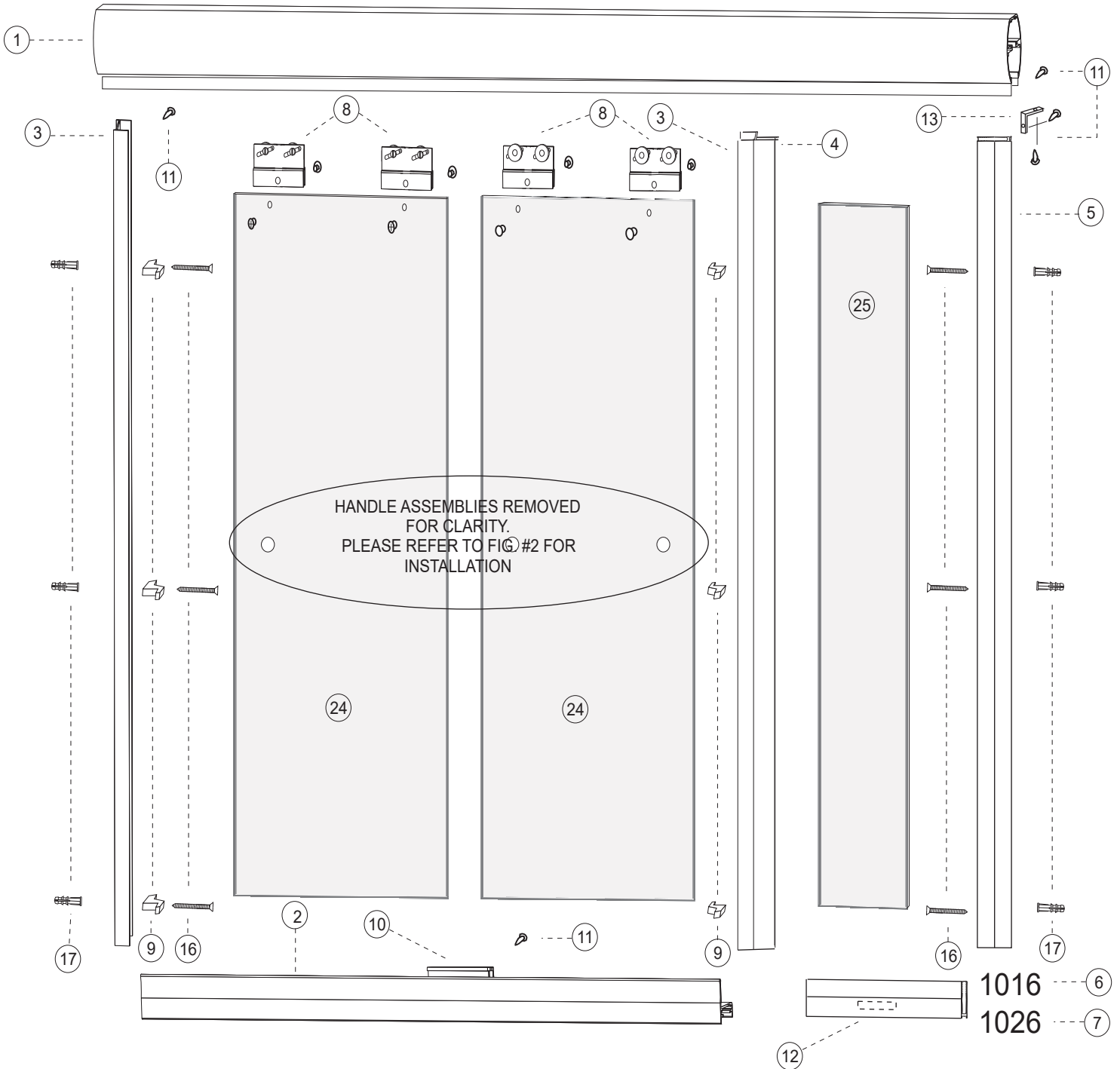

READ ENTIRE MANUAL BEFORE INSTALLATION AND OPERATION

Warnings and General Shower Door Information



**SAFETY
WARNINGS:**



READ AND FOLLOW INSTRUCTIONS: Failure to follow all instructions, warnings and guidelines may result in serious injury or death, may cause water damage, and will void the terms of your warranty.

General Safety and Installation Policies

Before Installation:

- **Proper Size:** Ensure the enclosure is the proper size for your opening prior to beginning installation.
- **Safe Installation:** Some units may require two or more people to safely install the enclosure properly.
- **Packaging:** It is recommended to retain all packaging and other materials until installation is complete in the event of a return.
- **Inspect:** Installer should inventory all parts or components and inspect them for damage prior to beginning installation.
- **Sharp Edges:** Exposed ends of aluminum and other hard components can be rough, sharp or jagged due to the processes of cutting, drilling, notching, etc. Sharp ends must be deburred, smoothed or rounded by the installer before installation.
- **Safety equipment and tools:** Have all necessary safety equipment (glasses and gloves) and proper tools for the installation. The installer is responsible for determining the correct drill bit(s) for the installation.
- **New Tile:** We recommend that you allow at least 2 days (48 hours) for the tile cement and grout to dry before installing enclosure.

During Installation



- **Proper backing:** Shower doors are heavy. Therefore, glazing channels, fillers, hinges and headers blocks (structural components) should be secured to studs or solid backing beneath the tile or decorative substrate. Fasteners should screw directly into the backing. Wall anchors are provided primarily to separate screws from tile to reduce the possibility of cracking.

- **Tempered glass:** Glass can break. Shower door panels are tempered to ASTM C1048 specifications as required by building codes. Glass is tempered to greatly increase its strength and to make it fragment into smaller and lighter pieces reducing the possibility of injury in the event that the glass does break. Tempered glass will break and may cause bodily injury if you attempt to cut, drill, mill or alter it in any way. Care must be taken when handling tempered glass. Pay special attention to protect all edges of the glass from contact with hard surfaces.
- **Horizontal surfaces and installation holes:** Avoid drilling into the horizontal surfaces of tubs or showers unless it is required for the structural integrity of the unit. If you drill into horizontal surfaces, always generously caulk the holes, anchors, screws and on top of the screw head. If this is not done, or is done improperly, water damage can occur under the tile or substrate.
- **Weep holes in horizontal channels:** Drilling 3/8" weep holes on the inside of horizontal channels is recommended to allow any moisture build-up inside a channel to exit the channel. Due to varying installation conditions and installer's/owner's personal preference, however, we do not drill them in the factory.
- **Sliding and swinging glass doors:** A door may be improperly installed if it hits or scrapes against bathroom obstructions (toilets or cabinets) or any metal or glass components of the shower door itself. This could lead to glass breakage or serious injury. The installer must correct the deficiencies before allowing the door to be used.
- **Surface conditions:** Most shower door designs allow for out-of-square or unlevel installation. Generally, any outage more than 3/8" that was not identified during the ordering process is outside of these allowances and can result in an improper installation.

Caulking/Siliconing the Unit:

- Always clean all contact surfaces before caulking and use a high grade 100% silicone for best results.
- After installation, at a minimum, caulk the entire outside perimeter of the unit where the unit touches walls, sills, and step-ups, etc. Also caulk any vertical joints between metal components where water build-up inside of the channels could leak out.

After Installation:

- **Curing times:** Adhere to manufacturers' recommended curing times for VHB tapes, silicones and any other adhesives, coatings or chemicals used during installation. Unless otherwise stated, it is recommended to wait 72 hours before using the enclosure.
- **Normal wear and tear:** Although these enclosures are designed to last for years, certain items (such as the polycarbonate seals and door sweeps) may need to be replaced as they show signs of aging and wear.

General Disclaimers

- **Shower Doors are not watertight:** Consumers should understand that a shower door is not watertight. The amount of water that can escape your shower can vary greatly based on shower/tub size, configuration of shower head(s), type of thresholds and drains and by the type of shower door itself. Heavy glass units with no or limited vinyl seals, for example, can allow water to escape under normal conditions. Doors with more metal and seals generally provide more water protection. Excessive water pressure or directing shower heads or hand held sprays directly at doors or joints is not a normal shower conditions and can result in leaks.
- **Towel bars, handles and accessories** are in no way considered to be grab bars or other bracing or fall prevention mechanisms. The intent of these accessories is to facilitate proper operation or enhance the esthetics and functionality of the unit.

Owners Manual:

Refer to your Owners Manual for general installation and cleaning and care instructions. If a copy of the Owners Manual was not included, you can download one on the RESOURCES page of our website.

Questions or Comments:

1-800-843-3332

Installation Instructions for the Estate Collection

Model: ESE180 / ETE180 (80 panel sliding enclosure w/in-line panel.)

Drawing #: 6152

Rev. Date: 11-03-05



FIG.# 2 - Top View

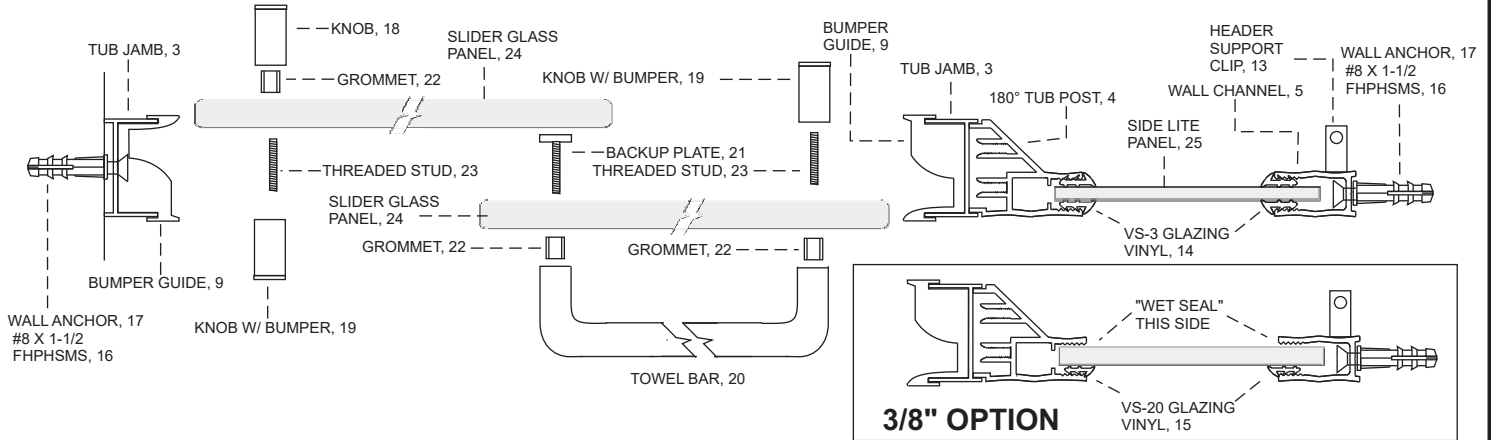

FIG. #3 - Tub Jamb Assembly

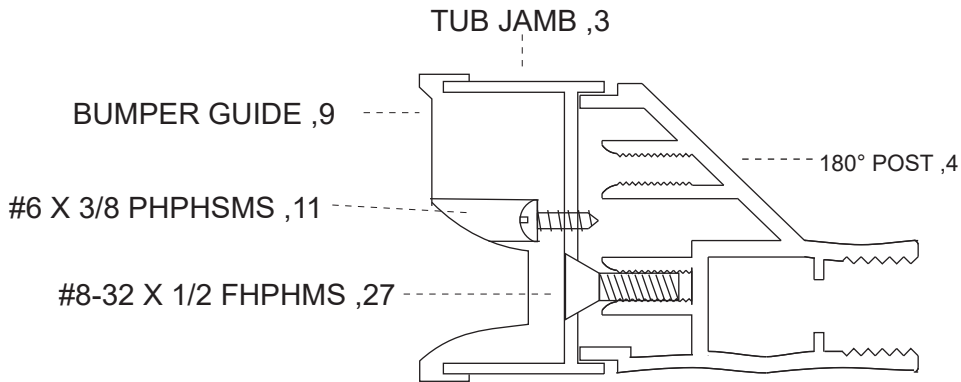
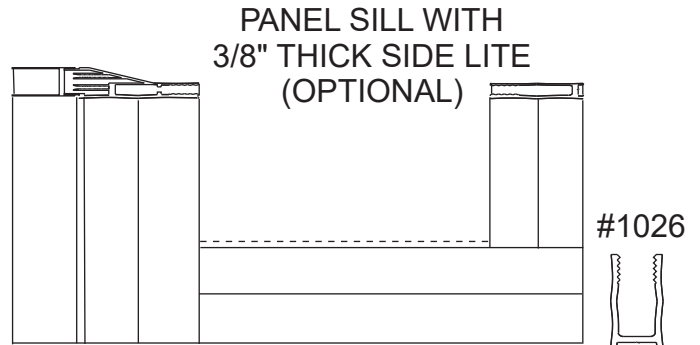

FIG. #4 - Panel Sill Assembly



Installation Instructions for the Estate Collection

Model: ESE180 / ETE180 (60 panel sliding enclosure w/in-line panel.)

Drawing #: 6152

Rev. Date: 11-03-05



FIG. #5 - Wall Channel / Header Assembly

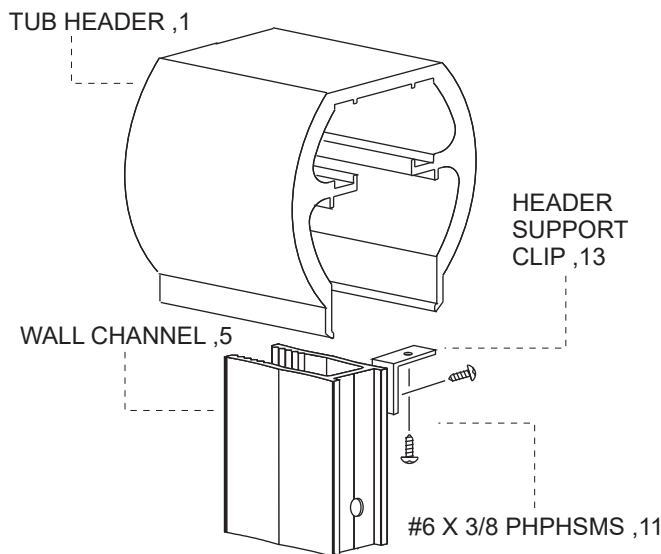

FIG. #6 - Hanger Bracket Assembly

SPECIAL NOTE:

If for some reason the rollers need to be reversed to the opposite side of the glass, the entire hanger bracket assembly must be removed and reinstalled. The rollers must remain on the same side of the bracket that they are assembled.

Screw heads are all on the same side.

Nylon rollers are all on the same side.

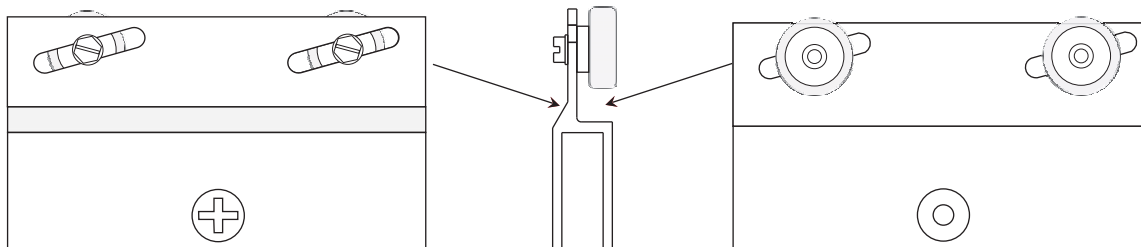
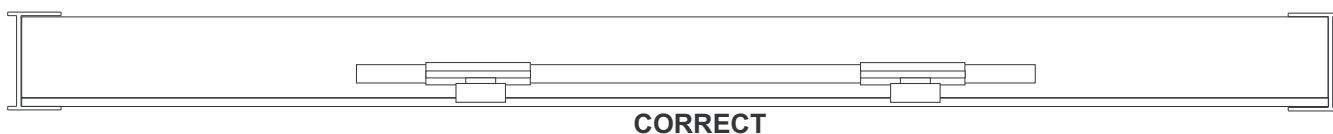

FIG. #7 Top View - Looking Down at the sill with Panel Installed In Header.



Installation Instructions for the Estate Collection

Model: ESE180 / ETE180 (180° panel sliding enclosure w/in-line panel.)

Drawing #: 6152

Rev. Date: 11-03-05



6152 ESE180 / ETE180 - Parts List

ITEM #	PART #	DESCRIPTION	QTY	ITEM #	PART #	DESCRIPTION	QTY
1	1052	Tub Header	1	15	4033	VS-20 Glazing Vinyl (3/8" side lite)	3
2	1062	Stay Clean Sill	1	16	2101	#8 X 1-1/2 FHPHMS	6
3	1051	Tub Jamb	2	17	2217	3/16" Wall Anchors	6
4	1023	180° Post	1	18	2384	Knob	1
5	1026	Wall Channel	1	19	2385	Knob W/ Bumper	2
6	1016	Panel Sill (1/4" side lite)	1	20	XXXX	Towel Bar	1
7	1026	Panel Sill (3/8" side lie)	1	21	XXXX	Back Up Plate	1
8	2275	Hanger Bracket	4	22	XXXX	Grommet	3
9	2223	Bumper Guide	6	23	XXXX	Threaded Stud	2
10	2207	Center Guide	1	24	XXXX	Slider Glass Panels	2
11	2102	#6 X 3/8 PHPHMS	6	25	XXXX	Side lite Glass Panel	1
12	2203	Setting Block	1	26	4032	TF-3 T-Fin	1
13	2019	Header Support Clip	1	27	2103	#8-32 X 1/2 FHPHMS	3
14	4013	VS-3 Glazing Vinyl (1/4" side lite)	4	28	2215	Adjustment Wrench	1

STEP 1 -- CENTERLINE:

Locate as accurately as possible the centerline, (C/L), of the shower and mark it with a water soluble marker. In most installations the Stay Clean Sill, (ITEM #2), is centered over and parallel to the C/L. Center the Tub Jamb with only 3- holes in it, (ITEM #3), over the centerline and against the shower head sidewall. Using a level, plumb the jamb, then mark the bottom hole location only, using the predrilled factory hole as a template. Drill the single bottom hole using a 3/16" drill bit, (use carbide tipped if going into tile, marble or any type of masonry material). Insert one Wall Anchor, (ITEM #17), into the hole, then secure the Tub Jamb with 1- #8 X 1-1/2" FHPHMS, (ITEM #16) install in the screw through a Bumper Guide, (ITEM #9).

NOTE: Tighten screw so that it is snug, but so that the Tub Jamb may be moved side to side at the top. This will allow for final adjustment later. Use two or three strips of masking tape across the Tub Jamb to the wall to hold the jamb from moving during installation.

Installation Instructions for the Estate Collection

Model: ESE180 / ETE180 (180° panel sliding enclosure w/in-line panel.)

Drawing #: 6152

Rev. Date: 11-03-05



STEP 2 -- STAY CLEAN SILL:

Measure the combined widths of the slider glass panels and subtract 7/16". This is the installed length of the Stay Clean Sill. (Example: Two 30" wide panels equals 60" combined width, subtract 7/16" = 59-9/16"). At this time, calculate the measurement, and cut Stay Clean Sill, (ITEM #2), to this length. Next, find the exact middle of the Stay Clean Sill. Using the factory hole in the Center Guide, (ITEM #10), as a template, mark the hole onto the Stay Clean Sill and drill with a #32 wire gauge drill bit. NOTE: Do not attach Center Guide at this time. Set the sill assembly on the shower or tub base by inserting the Stay Clean Sill into the legs of the Tub Jamb and align over centerline. Temporarily hold sill in place with masking tape. Take the second Tub Jamb that has 6- holes in it, (ITEM #3), and attach it to the 180° Tub Post, (ITEM #4), by orienting the 3- large holes to the outside of the shower, and attaching with 3- #8-32 X 1/2 FHPHSMS, (ITEM #27). Attach 3- Bumper Guides, (ITEM #9), to the Tub Jamb by first orienting the guides to receive the outside sliding panel and securing with #6 X 3/8 PHPHSMS, (ITEM #11) into the 3 remaining small holes. See (Fig. #2 & 3).

STEP 3 -- PANEL SILL (1/4" Side Lite):

Measure the width of the Side Lite Panel, (ITEM #25) and add 3/4" to this measurement. Cut the Panel Sill, (ITEM #6) to this dimension. Temporarily set the 180° Post assembly in place over the end of the Stay Clean Sill. Please note that the Panel Sill as well as the Wall Channel that has yet to be installed, will set outside of the centerline. Insert the Panel Sill into the 180° Post and align all parts to the wall to determine location of the Wall Channel. Attach the Header Support Clip, (ITEM #13), flush to the end of the Wall Channel, (ITEM #5), as shown in (FIG. #2 & 5). Secure clip with one #6 X 3/8" PHPHSMS, (ITEM #11). After this is done, insert Wall Channel, (ITEM #5) over open end of the Panel Sill and against the wall. Plumb Wall Channel and secure to wall by drilling three 3/16" holes and attach with three #8 X 1 1/2 FHPHSMS and anchors (ITEM #16 & #17).

STEP 4 - PANEL SILL (3/8" Side Lite):

Temporarily place 180° Tub Post, (ITEM #4), with Tub Jamb attached, in position at the end of the Stay Clean Sill. Please note that the Panel Sill fits between the 180° Post and the wall, NOT between the 180° Post and the Wall Channel. At this time, measure between the post and the wall and cut the Panel Sill, (ITEM #7), to size. Realign the Stay Clean Sill, the 180° Tub Post, and the Panel Sill to determine the location of the Wall Channel. Please note that the Panel Sill as well as the Wall Channel that has yet to be installed, will set outside of the centerline. Remove the 180° Post without disturbing the Panel Sill. Temporarily hold the panel sill in place with masking tape. Set the Wall Channel, (ITEM #5), on top of the Panel Sill, and against the wall, then plumb with a level. Mark the channels' predrilled hole locations on the wall and drill with a 3/16" drill bit. Insert three Wall Anchors, (ITEM #17), then realign the channel with the holes and secure with three #8 X 1-1/2" FHPHSMS, (ITEM #16).

STEP 5 -- WALL CHANNEL:

After the Wall Channel is secure, apply sealant to the inside of the Panel Sill to plug each end then insert a Setting Block, (ITEM #12), into the Panel Sill to protect the bottom of the glass panel. Please note that the Setting Block is oversized so that it may be recut into as many blocks as necessary. Remove masking tape from the Panel Sill and set the 180° Glass Panel into the Panel Sill and into the Wall Channel. Temporarily hold the post and glass panel in a plumb position by inserting 1 or 2 inches of Glazing Vinyl into the top of both posts. NOTE: Do not cut vinyl at this time.

Installation Instructions for the Estate Collection

Model: ESE180 / ETE180 (180° panel sliding enclosure w/in-line panel.)

Drawing #: 6152

Rev. Date: 11-03-05



STEP 6 -- TUB HEADER:

Measure wall to wall at the top of the vertical posts, then subtract 1/16" from this dimension and cut the Tub Header, (ITEM #1), to it's finished length. Set the header in place over the top of the Tub Jamb and Wall Channel with the Header Support Clip. Be sure that the roller channels of the header are resting firmly on the verticals. Secure Header at each wall by drilling through the Header into the verticals with a #32 wire gauge drill bit. Secure with 1 - #6 X 3/8 PHPHSMS, (ITEM #11). Using a level, plumb the 180° post combination and secure to the header from the inside of the shower by drilling through the header into the post with a #32 wire gauge drill bit. Secure with 1- #6 X 3/8" PHPHSMS, (ITEM #11). Center the 180° Glass Panel between the posts and finish glazing with 4- VS-3 Glazing Vinyl, (ITEM #14), the verticals only and "Wet Seal" the Panel Sill at the bottom with silicone caulking. FOR 3/8" THICK SIDELITE: Gla the outside verticals and bottom with Clear VS-20, (ITEM #15), then "Wet Seal" the inside with silicone caulking . See (FIG. #2).

STEP 7 -- SLIDING PANELS:

Make sure that the Tub Jamb with only one screw in it is snug, but still is able to move side to side. Hang the outside panel only in place in the Header. Make sure that the rollers are firmly seated in the Header roller channel. Slide it all the way towards the fully secured Tub Jamb.

STEP 8 -- PANEL ALIGNMENT:

Standing outside of the shower, hold the Header at the top where it meets the unsecured Tub Jamb. BE VERY CAREFUL TO KEEP CONTROL OF THE HEADER SO THAT THE SLIDING GLASS PANELS CAN NOT FA. Slowly, move the sliding panel to the middle of the opening. Adjust the header side to side, seeking a point where the outside face of the panel laying against the vertical leg of the Stay Clean Sill, exactly parallels it. The full width of the glass panel must contact the T-Fin of the Stay Clean Sill, not hitting on one edge or the other only. Now the panel is tracking on the same line as the Stay Clean Sill. See (FIG. #7). Mark the position of the Tub Jamb onto the wall. Slid the panel back to the secured Tub Jamb and remove the sliding panel and set it a safe place. Move the Tub Jamb back to the marked location on the wall and mark the final two hole locations. Remove the Tub Jamb and drill the holes with a 3/16" drill bit. Insert two Wall Anchors, (Item #17). Realign the Tub Jamb and secure with three #8 X 1-1/2 FHPHSMS, (Item #16), attaching a Bumper Guide, (Item #9), with each screw. See (Fig. #1). Make sure the Bump Guides are oriented to accept the proper panel. Install both of the sliding glass panels as you did earlier in this step, then install the Center Guide, (Item #10).

STEP 9 -- TOWEL BAR AND KNOBS:

The inside sliding panel, when closed, must be at the shower head wall so that it can deflect water away from the overlap of the panels at the center of the enclosure. Thus, the outside panel must be away from the shower head wall when closed. For the pull assemblies, start by sliding the glass panels to their proper closed position. You will notice that the center hole is inaccessible because of the overlap in the panels. Make it accessible by sliding each panel to it's opposite wall. Now the hole is at the outside edge. Begin installing the pull assemblies with the panels in this position. Start by installing the Back up Plate through the exposed hole on the outside panel, place one Plastic Spacer in the hole followed from the inside with a Back Up Plate into the corresponding hole in the Towel Bar on the outside of the panel for proper orientation and assembly slide the panels back to their proper positions and simply follow the detailed drawing in (Fig. #2).

STEP 10 -- CAULKING:

Apply a bead of caulk along the entire inside of the enclosure where it meets the walls and base. Caulk the joint where the each Tub Jamb meets the Stay Clean Sill. Apply caulk at the joints where the Panel Sill meets both vertical